

Quick Installation Guide

Unified AC Dual-band Outdoor PoE Access Point

DWL-8720AP

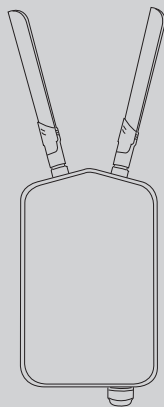

Contents

English	1
中文	5

Before You Begin

This installation guide provides instructions for installing the DWL-8720AP on your network. Additional documentation is also available on the D-Link support website.

Package Contents

This DWL-8720AP package includes the following items:

- DWL-8720AP Access Point
- Mounting Plate and Hardware (U-bolts and nut fasteners, screws and washers)
- Grounding Wire
- Console Cable
- Quick Start Guide

If any of the above items are damaged or missing, please contact your local D-Link reseller.

Note: To power the unit, use an 802.3af or 802.3at PoE switch or PoE injector. This product is intended to be supplied by a LPS (Limited Power Source) marked UL Listed Power Unit, and its output is rated at 48 V DC (PoE), 0.6 A min., and has a TMA of 60 °C.

System Requirements

- Computers with Windows®, Macintosh®, or Linux-based operating systems with an installed Ethernet Adapter.
- Internet Explorer 11, Safari 7, Firefox 28, or Google Chrome 33 and above (for configuration).

Hardware Overview

LED Indicators

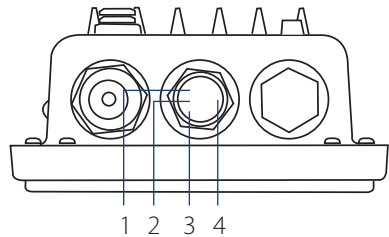

Figure 1: LED Indicators

Note: For the LED positions, please unscrew the protective cap to line up the device with the diagram above.

#	LED	Description
1	LAN (PoE)	Green (Solid) - Link preset Green (Flashing) - Sending or receiving packets
2	2.4 GHz	Green (Solid) - Device's 2.4 GHz band is operating successfully Green (Flashing) - Sending or receiving packets
3	5 GHz	Green (Solid) - Device's 5 GHz band is operating successfully Green (Flashing) - Sending or receiving packets
4	Power	Green (Solid) - Device operational Red (Solid) - Device is booting up or has malfunctioned

Table 1: LED Description

Interface Connectors

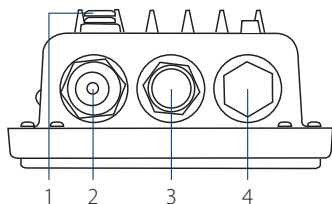

Figure 2: Bottom Connectors

#	Connector	Description
1	Vent	Repels liquid and particles while allowing air to pass through
2	LAN (PoE) Port	Gigabit RJ-45 port for data and Power over Ethernet (PoE)
3	Reset	Press and hold for 10 seconds to factory reset the device
4	Console Port	Console port to connect to the DWL-8720AP using a RJ-45 to serial cable

Table 2: Interface Description

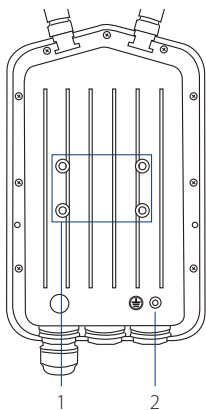

Figure 3: Rear Connectors

#	Connector	Description
1	Wall/Pole Mount	Mount to connect to the mounting plate on a wall or a pole
2	Grounding Wire	Connect a grounding wire to help prevent device damage due to shorts and lightning strikes

Table 3: Interface Description

Installation

Using Power over Ethernet (PoE)

1. Use a standard Ethernet cable to connect the LAN1 (PoE) port on the DWL-8720AP to a PoE power source device such as an 802.3af or 802.3at PoE switch or PoE injector.

Note: If you require a PoE injector such as D-Link's DPE-311G1, please contact your reseller to order it.

Configuration

Manual Configuration

Note: D-Link recommends manually configuring the device before mounting it. The management computer, DHCP server and DWL-8720AP must be in the same subnet.

Use the following method to access the web user interface:

Connecting through Ethernet

1. Use an Ethernet cable to connect the DWL-8720AP to the management computer, or to the switch or router the management computer is connected to.
2. Open a web browser and enter the IP address **10.90.90.91** and press **Enter**.

3. Log in to the administration user interface. The default login information is

Username: **admin**
 Password: **admin**

4. You can now assign a static IP address, or you can use a DHCP server on your network to assign network information to the DWL-8720AP. The DHCP client on the DWL-8720AP is enabled by default.

Mounting

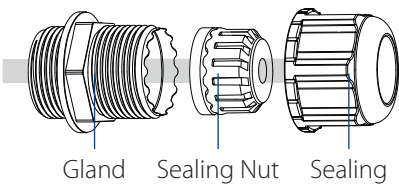

Figure 4: LAN Port Waterproof Enclosure

1. Connect an Ethernet Cable to the LAN (PoE) port on the DWL-8720AP. Use the LAN port waterproof enclosures to seal the ports.

Pole Mounting

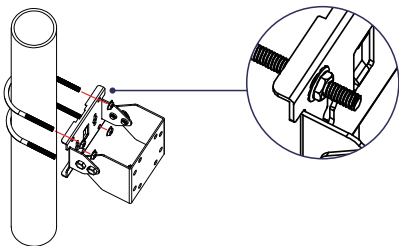

Figure 5: Attaching the Mounting Base

1. Secure the mount base to the pole using the U-bolt and the four included nut fasteners.

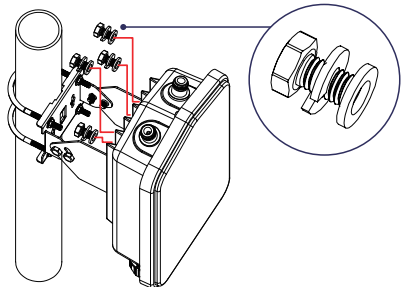

Figure 6: Mounting the Device

2. Align and attach the DWL-8720AP to the mounting base using the four included screws and washers.

Wall Mounting

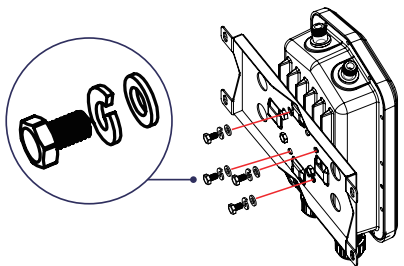

Figure 7: Attaching the Mounting Plate

1. Align and attach the DWL-8720AP to the mounting plate using the four included screws and washers.

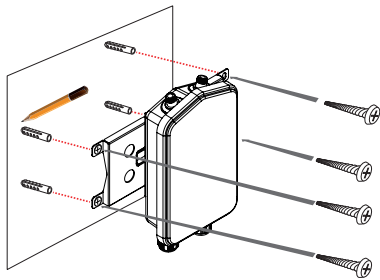

Figure 8: Mounting the Device

2. Use the mounting plate to mark where to drill the holes in the wall.
3. Drill holes on the markings and place the included anchors into the drilled holes.
4. Align and place the mounting plate on top of the anchors and use the included screws to secure the DWL-8720AP to the wall.

Connecting the Grounding Wire

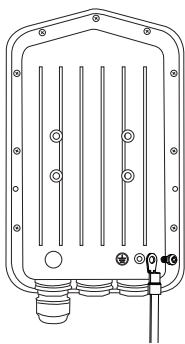

Figure 9: Attaching the Grounding Wire

1. A grounding wire is recommended to protect your device from lightning strikes

and the buildup of static electricity. Attach the grounding wire to the DWL-8720AP using the included screw.

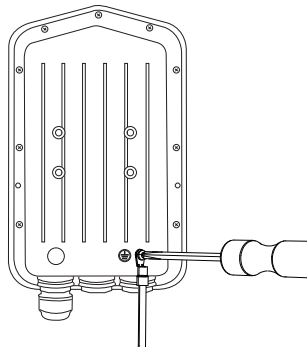

Figure 10: Attaching the Grounding Wire

2. Tighten the grounding wire to the DWL-8720AP until it is securely attached.

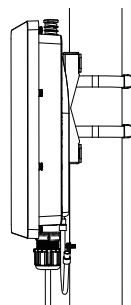

Figure 11: Attaching the Grounding Wire

3. Attach the other end of the grounding wire to either the wall or the pole mount. Ensure that the wall or the pole mount is connected to an electrical ground.

開始安裝

本安裝指南將協助您安裝DWL-8720AP無線基地台基本安裝說明，有關更多安裝說明，請參考使用者手冊或上D-Link官網查詢。

包裝內容清單

DWL-8720AP 產品包裝清單如下：

- DWL-8720AP 無線基地台
- 安裝組件與硬體（U-螺栓與螺母固定配件，螺釘和墊圈）
- 接地線
- Console線
- 快速安裝手冊

如有任何配件遺漏或是損壞，請洽經銷商聯繫。

注意：

DWL-8720AP供電請使用任何符合D-Link IEEE 802.3af或802.3at的PoE Switch或 PoE injector

本產品符合“L.P.S.” (or “Limited Power Source”) 的UL認證，額定電壓48Vdc (PoE), 0.6 A min., TMA = 60 degree C.

系統要求

- 電腦需具備 Windows®, Macintosh®, 或 Linux-based 操作系統並且安裝網路卡。
- Internet Explorer 11, Safari 7, Firefox 28, 或 Google Chrome 33 以上 (設定使用)。

硬體概觀

LED 指示燈



圖 1: LED 指示燈

注意：關於LED的位置，請將保護蓋旋轉開，並使設備與上圖對齊。

#	LED	敘述
1	LAN (PoE)	綠(恆亮) - 預設連線 綠(閃爍) - 發送/接受數據時
2	2.4 GHz	綠(恆亮) - 設備2.4 GHz 頻段正常運作中 綠(閃爍) - 發送/接受數據時
3	5 GHz	綠(恆亮) - 設備5 GHz 頻段正常運作中 綠(閃爍) - 發送/接受數據時
4	Power	綠(恆亮) - 設備運作中 紅(恆亮) - 設備正在 重新開機或故障

表 1: LED 敘述

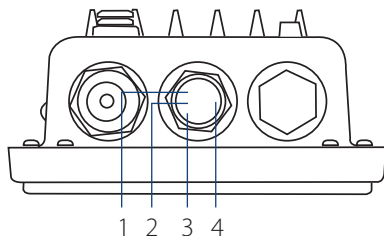
連接介面



圖 2: 底部連接埠

#	埠	Description
1	閘	平壓閘
2	LAN (PoE) 埠	Gigabit RJ-45埠提供資料傳輸與PoE供電
3	重置	按下約10秒將會恢復出廠預設值
4	Console 埠	請使用RJ-45轉serial cable的console線連接DWL-8720AP

表 2: 介面敘述

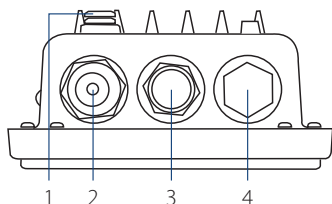

圖 3: 前面板連接埠

#	埠	敘述
1	壁掛式/立杆式	安裝以連接到壁掛座或是立桿上的固定支架

#	埠	敘述
2	接地線	連接接地線，以防止由短路或雷擊而損壞設備

表 3: 介面敘述

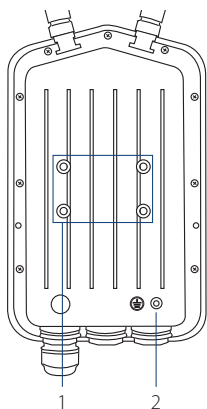
安裝

使用PoE供電

1. 請使用網路線將DWL-8720AP上的LAN1 (PoE)連接至PoE設備例如802.3af或802.3at PoE switch或PoE injector

注意: 若您想使用PoE injector例如D-Link's DPE-311GI, 請聯繫您的經銷商購買

設定

手動設定

注意: D-Link建議您再安裝前先手動設定，管理的電腦需要與DHCP、DWL-8720AP在同一網段

參考下列方法登入瀏覽器:

透過有線網路連線

1. 透過網路線連接進入管理介面,電腦需與基地台或路由器直接連線
2. 開啟網頁瀏覽器並且輸入IP位址 10.90.90.91
3. 登入管理者帳號密碼，預設登入資訊如下

Username: **admin**

Password: **admin**

4. 您可以設定固定的IP位址，或是您可以選用DHCP伺服器指派IP位址給DWL-8720AP. DWL-8720AP預設DHCP啟用

壁掛



圖 4: 網路埠防水外殼

1. 連接網路線到DWL-8720AP標示PoE的網路埠，請使用網路埠防水外殼

立杆安裝

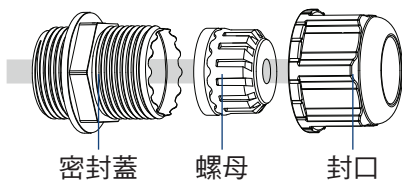

圖 5: 安裝底座

1. 使用U型螺栓和配件附的螺母將安裝底座固定到立桿。

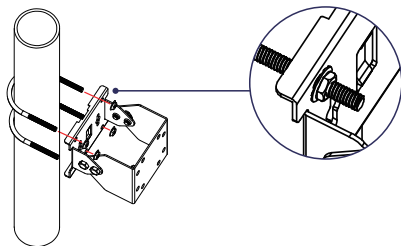

圖 6: 安裝設備

2. 使用配件附的四個螺絲和墊圈將DWL-8720AP對準並將其連接到安裝底座。

壁掛

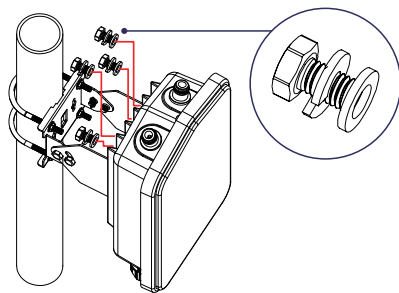

圖 7: 安裝壁掛固定支架

1. 使用配件附的四個螺絲和墊圈將DWL-8720AP對準並將其連接到安裝底座。

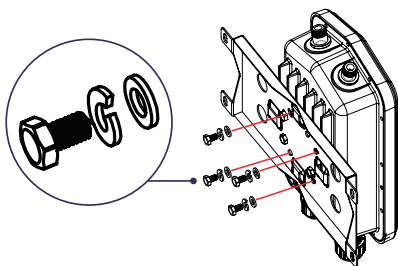

圖 8: 安裝設備

2. 使用壁掛固定支架在牆上標記預計鑽孔的位置。
3. 在標記上鑽孔，再使用配件附壁虎放入鑽孔中。
4. 對齊底座並將底座放在壁虎的上方，再使用配件的螺絲將DWL-8720AP固定在牆上。

連接接地線

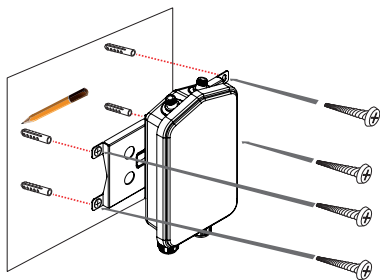

圖 9: 連接接地線

1. 建議使用接地線以保護設備避免受雷擊和靜電。使用配件的螺絲將接地線連接到DWL-8720AP。

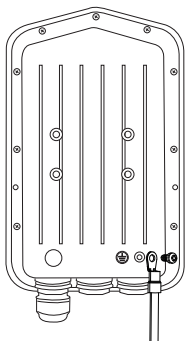

圖 10: 連接接地線

2. 鎖緊DWL-8720AP的接地線，直到牢固連接。

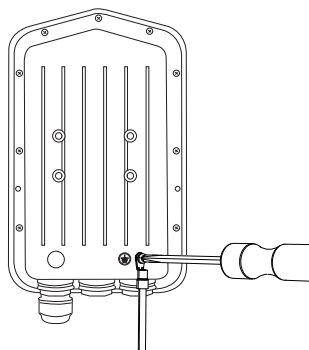

圖 11: 連接接地線

3. 將接地線的另一端連接到壁掛或立桿架上，確認接地線已正確接地。

D-Link 友訊科技 台灣分公司 技術支援資訊

如果您還有任何本使用手冊無法協助您解決的產品相關問題，台灣、香港或是澳門用戶可至網站、電子郵件或電話等方式與D-Link技術支援工程師聯絡。

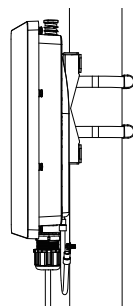
台灣D-Link免付費技術諮詢專線

台灣技術諮詢服務專線 0800-002-615

台灣手機付費電話 (02) 6600-0123#8715

台灣網站：<http://www.dlink.com.tw>

台灣電子郵件：dssqa_service@dlink.com.tw

產品保固期限、台灣技術諮詢時間、維修據點查詢，請參考
<http://www.dlinktw.com.tw/techsupport/> 網頁說明。

香港、澳門D-Link技術諮詢專線

技術諮詢：香港 852 - 8100 8892 / 澳門 853 - 2875 3423

香港網站：<http://www.dlink.com.hk>

香港電子郵件：service@cn.synnex-grp.com

香港、澳門維修據點查詢請參考<http://www.dlink.com.hk/contact.html> 網頁說明。

如果您是其他地區的用戶，請參考D-Link網站www.dlink.com 查詢全球各地分公司的聯絡資訊以取得相關支援服務。



了解更多
服務資訊

立即掃描QR code

注意！

依據 低功率電波輻射性電機管理辦法

第十二條：經型式認證合格之低功率射頻電機，非經許可，公司、商號或使用者均不得擅自變更頻率、加大功率或變更原設計之特性及功能。

第十四條：低功率射頻電機之使用不得影響飛航安全及干擾合法通信；經發現有干擾現象時，應立即停用，並改善至無干擾時方得繼續使用。

前項合法通信，指依電信規定作業之無線電信。低功率射頻電機須忍受合法通信或工業、科學及醫療用電波輻射性電機設備之干擾。

減少電磁波影響，請妥善使用。

在5.25-5.35赫赫頻帶內操作之無線資訊傳輸設備，限於室內使用。

避免電池持續處於充電狀態，可延長電池壽命，建議您請勿長時間插著充電器使用

Appendix - Statements

Federal Communication Commission Interference Statement

This equipment has been tested and found to comply with the limits for a Class B digital device, pursuant to Part 15 of the FCC Rules. These limits are designed to provide reasonable protection against harmful interference in a residential installation. This equipment generates, uses and can radiate radio frequency energy and, if not installed and used in accordance with the instructions, may cause harmful interference to radio communications. However, there is no guarantee that interference will not occur in a particular installation. If this equipment does cause harmful interference to radio or television reception, which can be determined by turning the equipment off and on, the user is encouraged to try to correct the interference by one of the following measures:

- Reorient or relocate the receiving antenna.
- Increase the separation between the equipment and receiver.
- Connect the equipment into an outlet on a circuit different from that to which the receiver is connected.
- Consult the dealer or an experienced radio/TV technician for help.

FCC Caution: Any changes or modifications not expressly approved by the party responsible for compliance could void the user's authority to operate this equipment.

This device complies with Part 15 of the FCC Rules. Operation is subject to the following two conditions: (1) This device may not cause harmful interference, and (2) this device must accept any interference received, including interference that may cause undesired operation.

- This device meets all the other requirements specified in Part 15E, Section 15.407 of the FCC Rules.

IMPORTANT NOTE:

Radiation Exposure Statement:

This equipment complies with FCC radiation exposure limits set forth for an uncontrolled environment. This equipment should be installed and operated with minimum distance 23.2 cm between the radiator & your body.

This transmitter must not be co-located or operating in conjunction with any other antenna or transmitter.

Country Code selection feature to be disabled for products marketed to the US/CANADA

Professional installation instruction

Please be advised that due to the unique function supplied by this product, the device is intended for use with our interactive entertainment software and licensed third-party only. The product will be distributed through controlled distribution channel and installed by trained professional and will not be sold directly to the general public through retail store.

1. Installation personal
This product is designed for specific application and needs to be installed by a qualified personal who has RF and related rule knowledge. The general user shall not attempt to install or change the setting.
2. Installation location
The product shall be installed at a location where the radiating antenna can be kept 23.2 cm from nearby person in normal operation condition to meet regulatory RF exposure requirement.
3. External antenna
Use only the antennas which have been approved by the applicant. The non-approved antenna(s) may produce unwanted spurious or excessive RF transmitting power which may lead to the violation of FCC limit and is prohibited.
4. Installation procedure
Please refer to user's manual for the detail.
5. Note to the installer:
To comply with the FCC U-NII Band 1 above 30-degree EIRP emission limit (21 dBm), installer must ensure that the final installation will not emit more than 21 dBm EIRP power 30-degrees above the horizon based on the antenna radiation pattern of the device.

Industry Canada statement

This device complies with Industry Canada's licence-exempt RSSs. Operation is subject to the following two conditions:

(1) This device may not cause interference; and (2) This device must accept any interference, including interference that may cause undesired operation of the device.

Le présent appareil est conforme aux CNR d'ISED applicables aux appareils radio exempts de licence. L'exploitation est autorisée aux deux conditions suivantes : (1) le dispositif ne doit pas produire de brouillage préjudiciable, et (2) ce dispositif doit accepter tout brouillage reçu, y compris un brouillage susceptible de provoquer un fonctionnement indésirable.

Caution :

(i) the device for operation in the band 5150-5250 MHz is only for indoor use to reduce the potential for harmful interference to co-channel mobile satellite systems;

(ii) for devices with detachable antenna(s), the maximum antenna gain permitted for devices in the bands 5250-5350 MHz and 5470-5725 MHz shall be such that the equipment still complies with the e.i.r.p. limit; (detachable antenna only)

(iii) for devices with detachable antenna(s), the maximum antenna gain permitted for devices in the band 5725-5850 MHz shall be such that the equipment still complies with the e.i.r.p. limits as appropriate; (detachable antenna only)

(iv) where applicable, antenna type(s), antenna models(s), and worst-case tilt angle(s) necessary to remain compliant with the e.i.r.p. elevation mask requirement set forth in section 6.2.2.3 shall be clearly indicated.

Avertissement:

Le guide d'utilisation des dispositifs pour réseaux locaux doit inclure des instructions précises sur les restrictions susmentionnées, notamment :

(i) les dispositifs fonctionnant dans la bande 5150-5250 MHz sont réservés uniquement pour une utilisation à l'intérieur afin de réduire les risques de brouillage préjudiciable aux systèmes de satellites mobiles utilisant les mêmes canaux;

(ii) pour les dispositifs munis d'antennes amovibles, le gain maximal d'antenne permis pour les dispositifs utilisant les bandes de 5 250 à 5 350 MHz et de 5 470 à 5 725 MHz doit être conforme à la limite de la p.i.r.e.; (detachable antenna only)

(iii) pour les dispositifs munis d'antennes amovibles, le gain maximal d'antenne permis (pour les dispositifs utilisant la bande de 5 725 à 5 850 MHz) doit être conforme à la limite de la p.i.r.e. spécifiée, selon le cas; (detachable antenna only)

(iv) lorsqu'il y a lieu, les types d'antennes (s'il y en a plusieurs), les numéros de modèle de l'antenne et les pires angles d'inclinaison nécessaires pour rester conforme à l'exigence de la p.i.r.e. applicable au masque d'élévation, énoncée à la section 6.2.2.3, doivent être clairement indiqués.

DETACHABLE ANTENNA USAGE

This radio transmitter (IC: 4216A-WL8720APA1 / DWL-8720APA1) has been approved by ISED to operate with the antenna type listed below with maximum permissible gain indicated. Antenna types not included in this list, having a gain greater than the maximum gain indicated for that type, are strictly prohibited for use with this device.

Le présent émetteur radio (IC: 4216A-WL8720APA1 / DWL-8720APA1) a été approuvé par ISED pour fonctionner avec les types d'antenne énumérés ci-dessous et ayant un gain admissible maximal. Les types d'antenne non inclus dans cette liste, et dont le gain est supérieur au gain maximal indiqué, sont strictement interdits pour l'exploitation de l'émetteur.

Approved antenna(s) list

Type	Gain	Brand	Manufacturer
Dipole	2.4~2.45GHz----3.5dBi 5.15~5.85GHz----6dBi	whayu	whayu

Radiation Exposure Statement:

This equipment complies with IC radiation exposure limits set forth for an uncontrolled environment.

This equipment should be installed and operated with minimum distance 26.6cm between the radiator & your body.

Déclaration d'exposition aux radiations:

Cet équipement est conforme aux limites d'exposition aux rayonnements IC établies pour un environnement non contrôlé. Cet équipement doit être installé et utilisé avec un minimum de 26.6 cm de distance entre la source de rayonnement et votre corps.

Professional installation instruction

1. Installation personal

This product is designed for specific application and needs to be installed by a qualified personal who has RF and related rule knowledge. The general user shall not attempt to install or change the setting.

2. Installation location

The product shall be installed at a location where the radiating antenna can be kept 26.6cm from nearby person in normal operation condition to meet regulatory RF exposure requirement.

3. External antenna

Use only the antennas which have been approved by the applicant. The non-approved antenna(s) may produce unwanted spurious or excessive RF transmitting power which may lead to the violation of ISED limit and is prohibited.

4. Installation procedure

Please refer to user's manual for the detail.

5. Warning

Please carefully select the installation position and make sure that the final output power does not exceed the limit set force in relevant rules. The violation of the rule could lead to serious federal penalty.

Instructions d'installation professionnelle

Veillez noter que l'appareil étant dédié à une fonction unique, il doit être utilisé avec notre logiciel propriétaire de divertissement interactif. Ce produit sera proposé par un réseau de distribution contrôlé et installé par des professionnels; il ne sera pas proposé au grand public par le réseau de la grande distribution.

1. Installation

Ce produit est destiné à un usage spécifique et doit être installé par un personnel qualifié maîtrisant les radiofréquences et les règles s'y rapportant. L'installation et les réglages ne doivent pas être modifiés par l'utilisateur final.

2. Emplacement d'installation

En usage normal, afin de respecter les exigences réglementaires concernant l'exposition aux radiofréquences, ce produit doit être installé de façon à respecter une distance de 26.6 cm entre l'antenne émettrice et les personnes.

3. Antenne externe.

Utiliser uniquement les antennes approuvées par le fabricant. L'utilisation d'autres antennes peut conduire à un niveau de rayonnement essentiel ou non essentiel dépassant les niveaux limites définis par IC, ce qui est interdit.

4. Procédure d'installation

Consulter le manuel d'utilisation.

5. Avertissement

Choisir avec soin la position d'installation et s'assurer que la puissance de sortie ne dépasse pas les limites en vigueur. La violation de cette règle peut conduire à de sérieuses pénalités fédérales.

經型式認證合格之低功率射頻電機，非經許可，公司，商號或使用者均不得擅自變更頻率、加大功率或變更原設計之特性及功能。

低功率射頻電機之使用不得影響飛航安全及干擾合法通信；經發現有干擾現象時，應立即停用，並改善至無干擾時方得繼續使用。

前項合法通信，指依電信法規定作業之無線電通信。低功率射頻電機須忍受合法通信或工業、科學及醫療用電波輻射性電機設備之干擾。

無線傳輸設備 (UNIT)

無線資訊傳輸設備忍受合法通信之干擾且不得干擾合法通信；如造成干擾，應立即停用，俟無干擾之虞，始得繼續使用。

無線資訊傳設備的製造廠商應確保頻率穩定性，如依製造廠商使用手冊上所述正常操作，發射的信號應維持於操作頻帶中。

本器材須經專業工程人員安裝及設定，始得設置使用，且不得直接販售給一般消費者

使用此產品時應避免影響附近雷達系統之操作。

高增益指向性天線只得應用於固定式點對點系統。

CE Mark Warning:

This is a Class B product. In a domestic environment, this product may cause radio interference, in which case the user may be required to take adequate measures.

1. A safety grounding system is necessary to protect your outdoor installation from lightning strikes and the build-up of static electricity.

When mounting the Outdoor Access Point on the pole or solid wall, you have to connect the Outdoor Access Point to the same grounding system* with the AC wall outlet.

* The grounding system must comply with the National Electrical Code and safety standards that apply in your country.

2. Instructions for the installation of that conductor to building earth by a SKILLED PERSON.

3. Please contact the authorized distributor of D-Link for related accessories (outdoor interconnection cable, cable gland, cable, etc.) for purchase and installation.

1. Un système de mise à la terre est nécessaire pour protéger votre installation extérieure de la foudre et de l'accumulation d'électricité statique. Lorsque vous installez le point d'accès extérieur sur un poteau ou un mur, vous devez le raccorder au même système de mise à la terre* que la prise électrique.

* Le système de mise à la terre doit être conforme aux réglementations et aux normes de sécurité en vigueur dans votre pays.

2. Instructions pour l'installation de ce conducteur à la terre du bâtiment par une PERSONNE QUALIFIÉE.

3. Contactez le distributeur agréé de D-Link pour les accessoires connexes (câble d'interconnexion extérieur, passe-câble, câble, etc.) pour l'achat et l'installation.

設備名稱：AC1300無線網路基地台，型號（型式）：DWL-8720AP						
Equipment name Type designation (Type)						
單元 Unit	限用物質及其化學符號 Restricted substances and its chemical symbols					
	鉛Lead (Pb)	汞Mercury (Hg)	鎘Cadmium (Cd)	六價鉻 Hexavalent chromium (Cr ⁺⁶)	多溴聯苯 Polybrominated biphenyls (PBB)	多溴二苯醚 Polybrominated diphenyl ethers (PBDE)
外殼	—	○	○	○	○	○
印刷電路板	—	○	○	○	○	○
天線	—	○	○	○	○	○
線材	—	○	○	○	○	○
<p>備考1. “超出0.1 wt %”及“超出0.01 wt %”係指限用物質之百分比含量超出百分比含量基準值。 Note 1 : “Exceeding 0.1 wt %” and “exceeding 0.01 wt %” indicate that the percentage content of the restricted substance exceeds the reference percentage value of presence condition.</p> <p>備考2. “○”係指該項限用物質之百分比含量未超出百分比含量基準值。 Note 2 : “○” indicates that the percentage content of the restricted substance does not exceed the percentage of reference value of presence.</p> <p>備考3. “—”係指該項限用物質為排除項目。 Note 3 : The “—” indicates that the restricted substance corresponds to the exemption.</p>						

D-Link[®]
Building Networks for People



Ver. 1.00(WW)_130x183
2020/07/29