

SHARP

Projector

P721Q-W/P601Q-W

User's Manual

Model No.
XP-P721Q-W/XP-P601Q-W

Table of Contents

IMPORTANT INFORMATION	4
Cable Information	4
Notice Concerning Electromagnetic Interference (EMI) (For other regions)	5
Disposing of Your Used Product	7
Laser Safety Caution.....	9
Risk Groups	10
Securing Personal Information.....	10
About the Symbols	11
Safety Cautions	12
Notes on Installation and Maintenance	22
Trademarks	26
INTRODUCTION	27
Package Overview.....	27
Standard Accessories	27
Product Overview	28
Connections	31
Control Panel.....	32
Remote Control.....	33
SETUP AND INSTALLATION	37
Connecting Sources to the Projector.....	37
Adjusting the Projector Image	38
Adjusting the Projector's Zoom and Focus.....	41
Adjusting the Projector Position.....	42
Remote Setup	43

USING THE PROJECTOR 45

Powering On / Off the Projector 45
Menu Navigation and Features 47
OSD Menu Tree..... 48
Image Menu 59
Display Menu 65
Communication Menu 71
System Menu 83
Information Menu 89
Language Menu..... 92

ADDITIONAL INFORMATION 93

Compatible Resolutions..... 93
RS232 Port Setting and Signals Connection..... 95
Image Size and Projection Distance 96
Ceiling Mount Installation..... 97
External Dimensions 98
Troubleshooting 99
LED Indicators and Lightning Messages..... 101
Specifications..... 102
RS232 Protocol Function List 105
REGISTER YOUR PROJECTOR! 106

IMPORTANT INFORMATION

Cable Information

Use shielded cables or cables attached ferrite cores so as not to interfere with radio and television reception.

Supplier's Declaration of Conformity

SHARP PROJECTOR, XP-P721Q-W / XP-P601Q-W

This device complies with Part 15 of the FCC Rules. Operation is subject to the following two conditions: (1) This device may not cause harmful interference, and (2) this device must accept any interference received, including interference that may cause undesired operation.

Responsible Party:

SHARP ELECTRONICS CORPORATION
100 Paragon Drive, Montvale, NJ 07645
TEL: (630) 467-3000 www.sharpnecdisplays.us

WARNING:

FCC Regulations state that any unauthorized changes or modifications to this equipment not expressly approved by the manufacturer could void the user's authority to operate this equipment.

NOTE:

This equipment has been tested and found to comply with the limits for a Class A digital device, pursuant to Part 15 of the FCC Rules. These limits are designed to provide reasonable protection against harmful interference when the equipment is operated in a commercial environment. This equipment generates, uses, and can radiate radio frequency energy and, if not installed and used in accordance with the instruction manual, may cause harmful interference to radio communications.

Operation of this equipment in a residential area is likely to cause harmful interference in which case the user will be required to correct the interference at his own expense.

U.S.A. ONLY

Notice Concerning Electromagnetic Interference (EMI) (For other regions)

WARNING:

Operation of this equipment in a residential environment could cause radio interference.

(For Customers in U.K.)

IMPORTANT

- The wires in this mains lead are coloured in accordance with the following code:

GREEN-AND-YELLOW: "Earth"

BLUE: "Neutral"

BROWN: "Live"

- As the colours of the wires in the mains lead of this apparatus may not correspond with the coloured markings identifying the terminals in your plug proceed as follows:
- The wire which is coloured GREEN-AND-YELLOW must be connected to the terminal in the plug which is marked by the letter **E** or by the safety earth symbol  or coloured green or green-and-yellow.
- The wire which is coloured BLUE must be connected to the terminal which is marked with the letter **N** or coloured black.
- The wire which is coloured BROWN must be connected to the terminal which is marked with the letter **L** or coloured red.
- Ensure that your equipment is connected correctly. If you are in any doubt consult a qualified electrician.

"WARNING: THIS APPARATUS MUST BE EARTHED."

WARNING

- **INGESTION HAZARD:** This product contains a button cell or coin battery.
- **DEATH** or serious injury can occur if ingested.
- A swallowed button cell or coin battery can cause **Internal Chemical Burns** in as little as **2 hours**.
- **KEEP** new and used batteries **OUT OF REACH of CHILDREN**
- **Seek immediate medical attention** if a battery is suspected to be swallowed or inserted inside any part of the body.



- The compatible battery type: CR2032
 - The nominal battery voltage: 3V
 - This product contains non-replaceable batteries.
-
- Remove and immediately recycle or dispose of used batteries according to local regulations and keep away from children. Do NOT dispose of batteries in household trash or incinerate.
 - Even used batteries may cause severe injury or death.
 - Call a local poison control center for treatment information.
 - The compatible battery type: CR2032
 - The nominal battery voltage: 3V
 - Non-rechargeable batteries are not to be recharged.
 - Do not force discharge, recharge, disassemble, heat above 95°F (35°C) or incinerate. Doing so may result in injury due to venting, leakage or explosion resulting in chemical burns.
 - This product contains non-replaceable batteries.

This product utilizes a CR coin Lithium battery which contains a Perchlorate material. Special handling for this material may apply,
See www.dtsc.ca.gov/hazardouswaste/perchlorate.

Disposing of Your Used Product



Information on the Disposal of this Equipment and its Batteries

IF YOU WISH TO DISPOSE OF THIS EQUIPMENT OR ITS BATTERIES, DO NOT USE THE ORDINARY WASTE BIN, AND DO NOT PUT THEM INTO A FIREPLACE!

Used electrical and electronic equipment and batteries should always be collected and treated SEPARATELY in accordance with local law.

Separate collection promotes an environment-friendly treatment, recycling of materials, and minimizing final disposal of waste. IMPROPER DISPOSAL can be harmful to human health and the environment due to certain substances! Take USED EQUIPMENT to a local, usually municipal, collection facility, where available.

Remove USED BATTERIES from equipment, and take them to a battery collection facility; usually a place where new batteries are sold.

If in doubt about disposal, contact your local authorities or dealer and ask for the correct method of disposal.

ONLY FOR USERS IN THE EUROPEAN UNION, AND SOME OTHER COUNTRIES; FOR INSTANCE NORWAY AND SWITZERLAND: Your participation in separate collection is requested by law.

The symbol shown above appears on electrical and electronic equipment and batteries (or the packaging) to remind users of this. If 'Hg' or 'Pb' appears below the symbol, this means that the battery contains traces of mercury (Hg) or lead (Pb), respectively.

Users from PRIVATE HOUSEHOLDS are requested to use existing return facilities for used equipment and batteries.

Batteries are collected at points of sale. Return is free of charge.

If the equipment has been used for BUSINESS PURPOSES, please contact your dealer who will inform you about take-back. You might be charged for the costs arising from take-back. Small equipment (and small quantities) might be taken back by your local collection facility. For Spain: Please contact the established collection system or your local authority for take-back of your used products.



Information on the Disposal of this Equipment and its Batteries

IF YOU WISH TO DISPOSE OF THIS EQUIPMENT, DO NOT USE THE ORDINARY WASTE BIN, AND DO NOT PUT THEM INTO A FIREPLACE!

Used electrical and electronic equipment and batteries should always be collected and treated SEPARATELY in accordance with local law.

Separate collection promotes an environment-friendly treatment, recycling of materials, and minimizing final disposal of waste. IMPROPER DISPOSAL can be harmful to human health and the environment due to certain substances! Take USED EQUIPMENT to a local, usually municipal, collection facility, where available.

This equipment contains a BATTERY which cannot be removed by the user. For battery exchange, please contact your dealer.

If in doubt about disposal, contact your local authorities or dealer and ask for the correct method of disposal.

ONLY FOR USERS IN THE EUROPEAN UNION, AND SOME OTHER COUNTRIES; FOR INSTANCE NORWAY AND SWITZERLAND: Your participation in separate collection is requested by law.

The symbol shown above appears on electrical and electronic equipment (or the packaging) to remind the users of this.

Users from PRIVATE HOUSEHOLDS are requested to use existing return facilities for used equipment. Return is free of charge.

If the equipment has been used for BUSINESS PURPOSES, please contact your dealer who will inform you about take-back. You might be charged for the costs arising from take-back. Small equipment (and small quantities) might be taken back by your local collection facility. For Spain: Please contact the established collection system or your local authority for take-back of your used products.

Laser Safety Caution

WARNING

CLASS 1 LASER PRODUCT [IEC 60825-1:2014]

CLASS 1 CONSUMER LASER PRODUCT OF EN 60825-1:2014+A11:2021 (For EU and UK)

- The laser module is equipped in this product. Use of controls or adjustments of procedures other than those specified herein may result in hazardous radiation exposure.
Laser energy exposure near aperture may cause burns.

- This product is classified as Class 1 of IEC 60825-1:2014.
- For EU and UK, EN 60825-1:2014+A11:2021 and EN 50689:2021 are also conformed.
- Obey the laws and regulations of your country in relation to the installation and management of the device.

For USA

Complies with 21 CFR 1040.10 and 1040.11 except for conformance as a Risk Group 2 LIP as defined in IEC 62471-5:Ed. 1.0. For more information see Laser Notice No. 57, dated May 8, 2019.

WARNING

- Do not allow to look into the projector beam at any distance from the projector. An adult should supervise the children to prevent exposure risks.
- Check that there is no one looking at the lens, when using the remote control for starting the projector.
- Do not look at the projected light using optical devices(binoculars, telescopes, magnifying glasses, reflectors, etc).
- [WARNING: MOUNT ABOVE THE HEADS OF CHILDREN.]
The use of a ceiling mount is recommended with this product to place it above the eyes of children.

- Outline of laser emitted from the built-in light module:
 - Wave length: 455 nm
 - Maximum power: 216W

Light Module

- A light module containing multiple laser diodes is equipped in the product as the light source.
- These laser diodes are sealed in the light module. No maintenance or service is required for the performance of the light module.
- End user is not allowed to replace the light module.
- Contact qualified distributor for light module replacement and further information.

Risk Groups

This projector is classified as either IEC/EN 62471-5:2015 risk group 2.

Risk group 2 (RG2)

WARNING

As with any bright light source, do not stare into the beam, RG2 IEC/EN 62471-5:2015.

To the dealer and the installer

1. To prevent the projector from falling, install it on the ceiling in a way with sufficient strength to withstand the combined weight of the projector and the ceiling mount unit for an extended period of time.
2. When installing the projector on the ceiling, be sure to do so correctly in accordance with the installation manual for the Ceiling Mount Unit. Be sure to use the fixed metal fittings and to tighten the screws securely.
3. To prevent the projector from falling, use fall prevention wires.
 - Use commercially available metal fittings to join the robust part of a building or construction and the security bar of the projector with the fall prevention wires.
 - Use commercially available metal fittings and fall prevention wires that have sufficient strength to withstand the combined weight of the projector and the ceiling mount unit.
 - Slightly slack off the fall prevention wires so as not to put a load on the projector.
 - Refer to the "Product Overview" for the location of the security bar. Please refer page 28 for details.

(for Germany only)

Machine Noise Information Regulation - 3. GPSGV,

The highest sound pressure level is less than 70 dB (A) in accordance with EN ISO 7779.

Information of the AUDIO OUT mini jack

The AUDIO OUT mini jack does not support earphone/headphone terminal.



Securing Personal Information

Personally identifiable information, such as IP addresses, may be saved on the projector. Before transferring or disposing of the projector, clear this data by performing [System] → [Reset] → [Reset All] on the on-screen menu.









About the Symbols

To ensure safe and proper use of the product, this manual uses a number of symbols to prevent injury to you and others as well as damage to property.

The symbols and their meanings are described below. Be sure to understand them thoroughly before reading this manual.

 WARNING	Failing to heed this symbol and handling the product erroneously could result in accidents leading to death or major injury.
 CAUTION	Failing to heed this symbol and handling the product erroneously could result in personal injury or damage to surrounding property.

Examples of symbols

	This symbol indicates you should be careful of electric shocks.
	This symbol indicates you should be careful of high temperatures.
	This symbol indicates something that must be prohibited.
	This symbol indicates something that must not be got wet.
	This symbol indicates you should not touch with wet hands.
	This symbol indicates something that must not be disassembled.
	This symbol indicates things you must do.
	This symbol indicates that the power cord should be unplugged from the power outlet.

Safety Cautions



Projected light



PROHIBITED

Projected light and the pictogram/label indicated on the cabinet

- Do not look into the projector's lens.
- Strong light that could damage your vision is projected when the projector is operating. Laser energy exposure near aperture may cause burns. Be especially careful when children are around.
- Do not look at the projected light using optical devices (magnifying glasses, reflectors, etc.). Doing so could result in vision impairment.
- Check that there is no one looking at the lens within the projection range before turning on the projector.
- Do not allow children to operate the projector alone. When a child is operating the projector an adult should always be present and watch the child carefully.
- The following labels are stuck on the projector.

Label 1

FDA additional warning label (For USA only)

"WARNING: MOUNT ABOVE THE HEADS OF CHILDREN."
Additional warning against eye exposure for close exposures less than 1 m.
"AVERTISSEMENT : INSTALLER AU-DESSUS DE LA TÊTE DES ENFANTS."
Avertissement supplémentaire contre l'exposition oculaire pour des expositions à une distance de moins de 1 m.
"警告：安裝在高於孩童頭頂處"
关于小于1 m近距離眼睛暴露的附加警告
「警告：安裝在高於兒童頭部處」
針對1 m 以下近距離眼睛接觸的額外警告

"WARNING: MOUNT ABOVE THE REACH AND SIGHT OF CHILDREN."

The use of a ceiling mount is recommended with this product to place it above the eye level of children.

Additional warning against eye exposure for close exposures less than 1 m.

Continue to next page

WARNING

Label 2 Laser explanatory label



Label Location

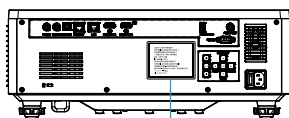
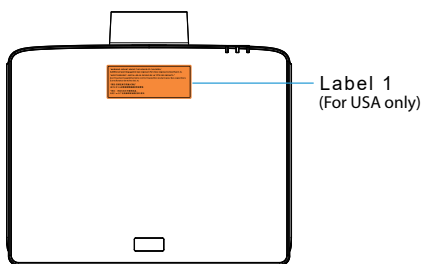

Label 2

- This product is classified as RG2 of IEC/EN 62471-5:2015.
- The below pictogram, that is indicated near the lens on the cabinet, describes this projector is categorized in the risk group 2 of IEC/EN 62471-5:2015. As with any bright light source, do not stare into the beam, RG2 IEC/EN 62471-5:2015.

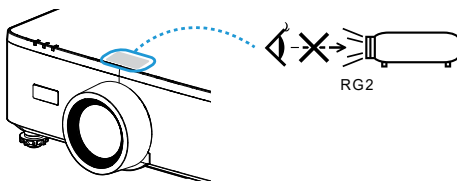

WARNING

Power supply



REQUIRED

Use a suitable voltage power supply.

- This projector is designed to be used with a 100–240 VAC, 50/60 Hz power supply. Before using the projector, check that the power supply to which the projector is to be connected meets these requirements.
- Use a power outlet as the projector's power supply. Do not connect the projector directly to electrical light wiring. Doing so is dangerous.



**MUST BE
EARTHED**

Connecting the power cord to earth

- This equipment is designed to be used in the condition of the power cord connected to earth. If the power cord is not connected to the earth, it may cause electric shock. Please make sure the power cord is connected to the wall outlet directly and earthed properly. Do not use a 2-pin plug converter adapter.
- Be sure to connect the projector and the computer (signal source) to the same earth point. If the projector and the computer (signal source) will be connected to different earth points, fluctuations in the earth potential may cause fire or smoke.



REQUIRED

Handling the power cord

- Please use the power cord supplied with this projector. If the supplied power cord does not satisfy requirements of your country's safety standard, and voltage and current for your region, make sure to use the power cord that conforms to and satisfies them.

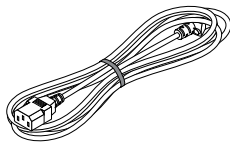

- The power cord you use must be approved by and comply with the safety standards of your country. Please refer to the page 103 about the power cord specification.
- For selecting an appropriate power cord, please check rated voltage for your region by yourself.



PROHIBITED

- The power cord included with this projector is exclusively for use with this projector. For safety, do not use it with other devices.

Continue to next page

WARNING



**HAZARDOUS
VOLTAGE**

- Handle the power cord with care. Damaging the cord could lead to fire or electric shock.

- Do not place heavy objects on the cord.
- Do not place the cord under the projector.
- Do not cover the cord with a rug, etc.
- Do not scratch or modify the cord.
- Do not bend, twist or pull the cord with excessive force.
- Do not apply heat to the cord.

Should the cord be damaged (exposed core wires, broken wires, etc.), ask your dealer to replace it.

- Do not touch the power plug should you hear thunder. Doing so could result in electric shock.

- Do not connect or disconnect the power cord with wet hands. Doing so could result in electric shock.



**DO NOT TOUCH
WITH WET
HANDS**

Installation



PROHIBITED

Do not use in places such as those described below.

- Do not use in places such as those described below. Doing so could lead to fire or electric shock.
 - Shaky tables, inclined surfaces or other unstable places.
 - Poorly ventilated spaces.
 - Near a radiator, other heat sources, or in direct sunshine.
 - Continual vibration areas.
 - Humid, dusty, steamy, or oily areas.
 - An environment where there are corrosive gases (sulfur dioxide, hydrogen sulfide, nitrogen dioxide, chlorine, ammonia, ozone, etc.).
 - Outdoors.
 - High-temperature environment where humidity changes rapidly and condensation is likely to occur.

Continue to next page

 **WARNING**



DO NOT WET



UNPLUG THE POWER CORD

- Do not use in places such as those described below where the projector could get wet. Doing so could lead to fire or electric shock.
 - Do not use in the rain or snow, on a seashore or waterfront, etc.
 - Do not use in a bathroom or shower room.
 - Do not install under equipment that discharges water, such as air conditioners.
 - Do not place vases or potted plants on the projector.
 - Do not place cups, cosmetics or medicines on the projector.
- Should water, etc. get inside the projector, first turn off the projector's power, then unplug the power cord from the power outlet and contact your dealer.



CAUTION

Installing suspended from the ceiling

- Consult your dealer for installing the projector on the ceiling. Special skills are required for ceiling installation. DO NOT perform installation work by people other than installers. Doing so may result in the projector falling and causing injury.
- We are not liable for any accident or/and damage resulting from improper installation or handling, misuse, modification, or natural disasters.
- When installed suspended from the ceiling, etc. do not hang from the projector. The projector could drop and cause injury.
- When installing suspended from the ceiling, use a power outlet that is within reach so the power cord can be easily plugged and unplugged.

On use



PROHIBITED









UNPLUG THE POWER CORD

Do not place objects inside the projector.

- Do not insert or drop metal or combustible objects or other foreign materials into the projector from the vents. Doing so could lead to fire or electric shock. Be particularly careful if there are children in the home. Should a foreign object get inside the projector, first turn off the projector's power, then unplug the power cord from the power outlet and contact your dealer.

WARNING

 <p>UNPLUG THE POWER CORD</p>	<p>Unplug the power cord if the projector malfunctions.</p> <ul style="list-style-type: none"> Should the projector emit smoke or strange odors or sounds, or if the projector has been dropped or the cabinet broken, turn off the projector's power, then unplug the power cord from the power outlet. Otherwise it may cause not only fire or electric shock but also serious damage to your eyesight or burns. Contact your dealer for repairs. Never try to repair the projector on your own. Doing so is dangerous.
 <p>DO NOT DISASSEMBLE</p>	<p>Do not disassemble the projector.</p> <ul style="list-style-type: none"> Do not remove or open the projector's cabinet. Also, do not modify the projector. There are high voltage areas in the projector. It may cause fire, electric shock, or laser light leakage, resulting in serious damage to your eyesight or burns. Have qualified service personnel perform inspection, adjustments and repairs of the interior.
 <p>PROHIBITED</p>  <p>CAUTION FOR HIGH TEMPERATURE</p>	<p>Do not place objects in front of the lens while the projector is operating.</p> <ul style="list-style-type: none"> Do not place objects in front of the lens that obstruct the light while the projector is operating. The object could get hot and be broken or catch fire. The below pictogram indicated on the cabinet means the precaution for avoiding to place objects in front of the projector lens. 
 <p>PROHIBITED</p>	<p>When cleaning the projector</p> <ul style="list-style-type: none"> Do not use flammable gas sprays to remove dust from the lens, cabinet, etc. Doing so could lead to fire.
 <p>PROHIBITED</p>	<p>Do not use in high security locations.</p> <ul style="list-style-type: none"> Usage of the product must not be accompanied by fatal risks or dangers that, could lead directly to death, personal injury, severe physical damage or other loss, including nuclear reaction control in nuclear facility, medical life support system, and missile launch control in a weapon system.



CAUTION

Power cord



REQUIRED

Handling the power cord

- The projector should be installed close to an easily accessible power outlet.
- When connecting the power cord to the projector's AC IN terminal, make sure the connector is fully and firmly inserted. Loose connection of the power cord could lead to fire or electric shock.



REQUIRED



UNPLUG THE
POWER CORD

Handling the power cord by following below to avoid fire or electric shock

- When connecting or disconnecting the power cord, pull the power cord out by holding onto its plug.
- Unplug the power cord from the power outlet before cleaning the product or when not planning to use the product for an extended time.
- When the power cord or plug is heat or damaged, unplug the power cord from the power outlet, and contact your dealer.



REQUIRED

Periodically clean dust and other debris from the power plug

- Failure to do so could result in fire or electric shock.



REQUIRED

Disconnect power cords and other cables before moving the projector

- Before moving the product, make sure the product power is off, then unplug the power cord from the power outlet and check that all cables connecting the product to other devices are disconnected.



PROHIBITED

Do not use the power cord with a power tap

- Adding an extension cord may lead to fire as a result of overheating.



CAUTION

On use



PROHIBITED

Do not use on networks subject to overvoltage.

- Connect the projector's HDBaseT port and LAN port to a network for which there is no risk of overvoltage being applied. Overvoltage applied to the HDBaseT or LAN port could result in electric shock.



REQUIRED

Lens shift, focus and zoom operations

- When shifting the lens or adjusting the focus or zoom, do so from either behind or the side of the projector. If adjustments are performed from the front, your eyes could be exposed to strong light and get injured.



PROHIBITED

Handling batteries

Incorrect usage of batteries can result in leaks or bursting.

- Use the specified batteries only.
- Insert batteries matching the (+) and (-) signs on each battery to the (+) and (-) signs of the battery compartment.
- Do not mix battery brands.
- Do not combine new and old batteries. This can shorten battery life or cause liquid leakage of batteries.
- Remove dead batteries immediately to prevent battery acid from leaking into the battery compartment.
If leaked battery fluid gets on your skin or clothing, rinse immediately and thoroughly. If it gets into your eye, bathe your eye well rather than rubbing and seek medical treatment immediately. Leaked battery fluid that gets into your eye or your clothing may cause a skin irritation or damage your eye.
- If you will not use the remote control for a long time, remove the batteries.
- Leaving a battery in an extremely high temperature surrounding environment, or a battery subject to extremely low air pressure, that can result in an explosion or the leakage of flammable liquid or gas.
- Properly dispose of depleted batteries. Disposal of a battery into water, fire, or a hot oven, or mechanically crushing, cutting, or modifying a battery can result in an explosion.
- Do not short-circuit the batteries.
- Do not charge the batteries. The batteries provided are not rechargeable.
- Contact your dealer or local authorities when disposing of batteries.

CAUTION



PROHIBITED



CAUTION
FOR HIGH
TEMPERATURE

About the vents

- Do not obstruct the projector's vents. Also, do not place such soft objects as paper or cloths underneath the projector. Doing so could lead to fire.
Leave sufficient space between the place where the projector is installed and its surroundings.
- Do not touch the exhaust vent area while projecting or immediately after projecting images. The exhaust vent area may be hot at this time and touching it could cause burns.



PROHIBITED

Moving the projector

- When moving the projector, do not hold the lens hood. The lens hood could become loose and the main unit could fall down, causing injuries.
- Do not put your hand into the recess of the connection terminal. The projector could be damaged or fall down, resulting in injuries.

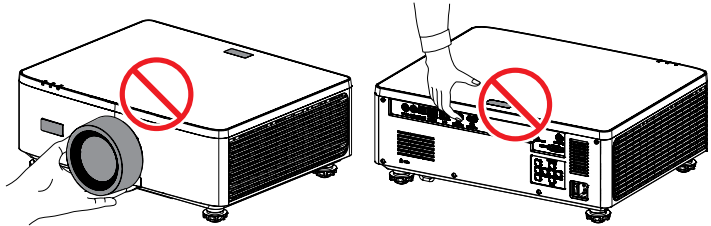

PROHIBITED

Do not push or climb on the product. Do not grab or hang onto the product. Do not rub or tap the product with hard objects. The product may fall, causing damage to the product or personal injury.



REQUIRED

Avoid locations with extreme temperatures and humidity

- Failure to do so could lead to fire or electric shock or damage to the projector. The usage environment for this projector is as follows:
 - The operating temperature: 0°C to 45°C / 32°F to 113°F / humidity: 10 to 85% (without condensation)
 - The storage temperature: -10°C to 60°C / 14°F to 140°F / humidity: 20 to 90% (without condensation)



CAUTION

Inspections and Cleaning



REQUIRED

Inspecting the projector and cleaning the inside

- Consult with your dealer about once per year for cleaning of the inside of the projector. Dust could accumulate inside of the projector if it is not cleaned for extended periods of time, leading to fires or malfunction.

3D



REQUIRED

Health precautions to users viewing 3D images

Before viewing, be sure to read health care precautions that may be found in the user's manual included with your 3D eyeglasses or your 3D compatible content such as Blu-ray Discs, video games, computer's video files and the like.

To avoid any adverse symptoms, heed the following:

- Do not use 3D eyeglasses for viewing any material other than 3D images.
- Allow a distance of 2 m/7 feet or greater between the screen and a user. Viewing 3D images from too close a distance can strain your eyes.
- Avoid viewing 3D images for a prolonged period of time. Take a break of 15 minutes or longer after every hour of viewing.
- If you or any member of your family has a history of light-sensitive seizures, consult a doctor before viewing 3D images.
- While viewing 3D images, if you get sick such as nausea, dizziness, queasiness, headache, eyestrain, blurry vision, convulsions, and numbness, stop viewing them. If symptoms still persist, consult a doctor.
- View 3D images from the front of the screen. Viewing from an angle may cause fatigue or eyestrain.

Notes on Installation and Maintenance

Do not install or store in such places as those described below.

- Locations that amplify vibrations and impacts
If installed in places where the vibrations from power sources and the like are conveyed, or in vehicles or on vessels, etc. the projector could be affected by vibrations or shocks that may damage internal parts and lead to malfunction.
- Close to high voltage power lines and power sources
It could disrupt the unit.
- Places where strong magnetic fields are generated
Doing so could lead to malfunction.
- Outdoors and places with humid or dust
Places exposed to oil smoke or steam
Places where corrosive gases are generated
Attached substances such as oil, chemicals and moisture may cause deformation or cracks of the cabinet, corrosion of the metal parts, or malfunction.

Cleaning the Lens

- The projector has a glass lens. Use a commercially available glass lens cleaner.
- Do not scratch or mar the lens surface as a glass lens is easily scratched.
- Never use alcohol or glass lens cleaner as doing so will cause damage to the glass lens surface.

WARNING

- Do not use a spray containing flammable gas to remove dust attached to the lens, etc. Doing so may result in fire.
- Turn off the power and unplug the power plug from the socket for cleaning. If the unit turns on while cleaning the lens, the strong light from the lens could damage your eyes. It could also burn your fingers.

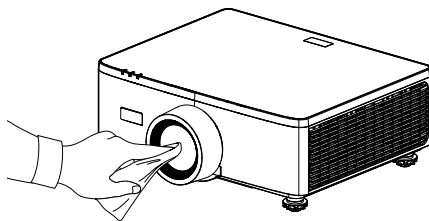

Cleaning the Cabinet

Turn off the projector, and unplug the projector before cleaning.

- Use a dry soft cloth to wipe dust off the cabinet.
If heavily soiled, use a mild detergent.
- Never use strong detergents or solvents such as alcohol or thinner.
- When cleaning the ventilation slits or the speaker using a vacuum cleaner, do not force the brush of the vacuum cleaner into the slits of the cabinet.

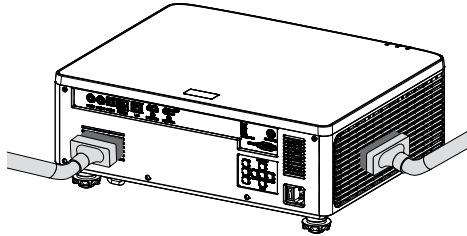

Vacuum the dust off the ventilation slits or the speaker.

- Poor ventilation caused by dust accumulation in ventilation openings can result in overheating and malfunction. These areas should be cleaned regularly.
- Do not scratch or hit the cabinet with your fingers or any hard objects.
- Contact your dealer for cleaning the inside of the projector.

Note: *Do not apply volatile agent such as insecticide on the cabinet, the lens, or the screen. Do not leave a rubber or vinyl product in prolonged contact with it. Otherwise the surface finish will be deteriorated or the coating may be stripped off.*

Cautions for ensuring the projector's performance

- If intense light like laser beams enters from the lens, it could lead to malfunction.
- Consult your dealer before using in places where much cigarette smoke or dust is present.
- This unit has a built-in air pressure sensor, and the "High Altitude Mode" will automatically switch to "On" depending on the altitude of the installation location. When the High Altitude Mode is switched to On, the cooling fan will rotate at high speed.
- If the High Altitude Mode does not switch to On even when the altitude exceeds 1500 m/5000 ft, manually switch "System" → "High Altitude" in the on-screen menu to "On".
- When the projector is used at high altitudes (places where the atmospheric pressure is low), it may be necessary to replace the optical parts sooner than usual.
- About moving the projector
Do not subject the projector to vibrations or strong shocks. The projector could be damaged otherwise.
- Do not use the tilt feet for purposes other than adjusting the projector's tilt. Improper handling, such as carrying the projector by the tilt feet or using it leaned against a wall, could lead to malfunction.
- The projector does not support stack installation. Do not stack projectors directly on top of each other. Failure to do so may cause damage or failure.
- Do not touch the surface of the projection lens with bare hands. Fingerprints or dirt on the surface of the projection lens will be enlarged and projected on the screen. Do not touch the surface of the projection lens.
- Do not unplug the power cord from the projector or the power outlet while projecting. It could lead to malfunction.
- About handling of the remote control
 - The remote control will not work if the projector's remote signal sensor or the remote control's signal transmitter is exposed to strong light or if there are obstacles between them that obstruct the signals.
 - Operate the remote control from within 6 meters (19.7 feet) from the projector, pointing it at the projector's remote signal sensor.
 - Do not drop the remote control or handle it improperly.
 - Do not let water or other liquids get on the remote control. Should the remote control get wet, wipe it off immediately.
 - Avoid using in hot and humid places as far as possible.
- Take measures to prevent external light from shining on the screen. Make sure only the light from the projector shines on the screen. The less external light on the screen, the higher the contrast and the more beautiful the images.
- About screens
Images will not be clear if there is dirt, scratches, discoloration, etc. on your screen. Handle the screen with care, protecting it from volatile substances, scratches and dirt.

- About Copyright of original projected pictures
Please note that using this projector for the purpose of commercial gain or the attraction of public attention in a venue such as a coffee shop or hotel and employing compression or expansion of the screen image with the following functions may raise concern about the infringement of copyrights which are protected by copyright law. [Aspect Ratio], [V Keystone / H Keystone], Magnifying feature and other similar features.

Power management function

The projector has power management functions. To reduce power consumption, the power management functions (1 and 2) are factory preset as shown below. To control the projector from an external device via a LAN or serial cable connection, use the on-screen menu to change the settings for 1 and 2.

1. STANDBY MODE (Factory preset: Normal Standby)

To control the projector from an external device, select [Network Standby] or [Sleep] for [Standby Mode].

(→ User's manual: page 83)

2. AUTO POWER OFF (Factory preset: 20 minutes)

To control the projector from an external device, select [0] for [Auto Power Off (min)].

(→ User's manual: page 84)

Trademarks

- The terms HDMI, HDMI High-Definition Multimedia Interface, HDMI Trade dress and the HDMI Logos are trademarks or registered trademarks of HDMI Licensing Administrator, Inc.



- HDBaseT³ logo are trademarks of the HDBaseT Alliance.



- DLP® and the DLP logo are trademarks or registered trademarks of Texas Instruments in the United States and other countries.
- Trademark PJLink is a trademark applied for trademark rights in Japan, the United States of America and other countries and areas.
- Blu-ray is a trademark of Blu-ray Disc Association.
- Crestron is a registered trademark of Crestron Electronics, Inc. of the United States.
- AMX is a registered trademark of AMX LLC of the United States.
- Ethernet is either a registered trademark or trademark of FUJIFILM Business Innovation Corporation.
- GPL/LGPL Software Licenses
The product includes software licensed under GNU General Public License (GPL), GNU Lesser General Public License (LGPL), and others.
For more information on each software, visit our web site.
https://www.sharp-nec-displays.com/dl/en/pj_manual/lineup.html
- Other product and company names mentioned in this user's manual may be the trademarks or registered trademarks of their respective holders.

INTRODUCTION

Package Overview

Carefully unpack and verify that you have the items listed below under standard accessories. Some of the items under optional accessories may not be available depending on the model, specification and your region of purchase. Please check with your place of purchase. Some accessories may vary from region to region.

The warranty card is only supplied in some specific regions. Please consult your dealer for detailed information.

Standard Accessories

Projector

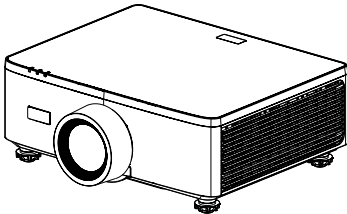

Remote control

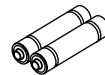

AAA Manganese batteries (x2)

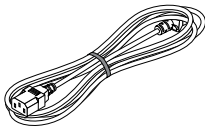

Power cord

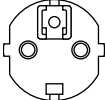
Plug type	
For USA	For EU
	

Documents

- Important Information
(For North America: TINS-0035VW01)
(For Other countries than North America: TINS-0035VW01 and TINS-0036VW01)
- Quick Setup Guide (TINS-0037VW01)
- Security Sticker (Use this sticker when security password is set on.)

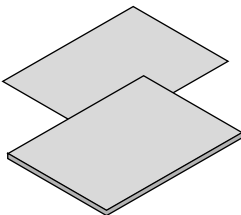

For North America only

Limited warranty

For customers in Europe

You will find our current valid Guarantee Policy on our Web Site:

<https://www.sharpnecdisplays.eu>

INTRODUCTION

Product Overview

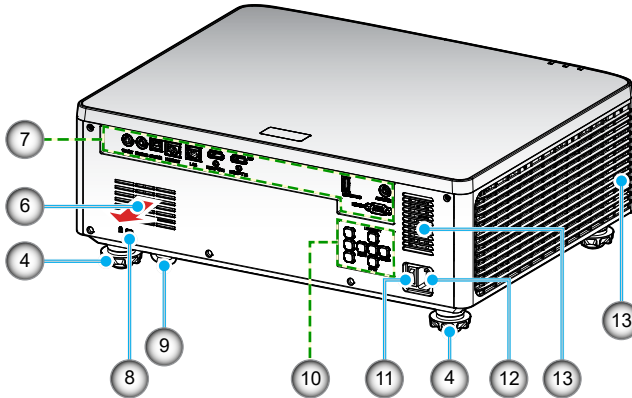
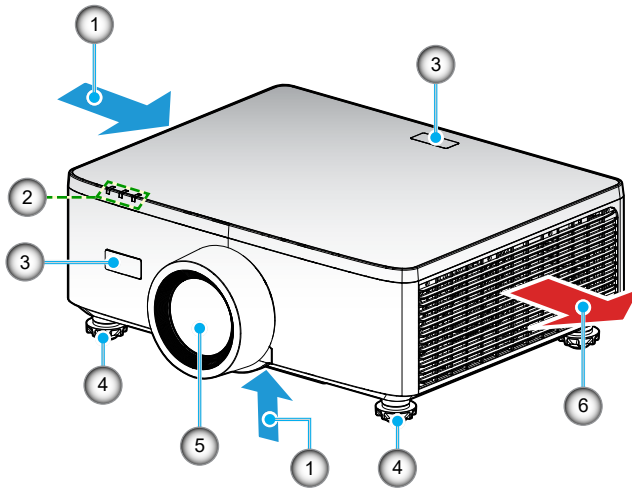

No.	Item	Function
1.	Ventilation (Inlet)	Take in outside air to cool the unit.
2.	LED Indicators	The indicator light turns on or blinks to relay the status of the projector.
3.	IR Receivers	Receive signals from the remote control.
4.	Tilt-Adjustment Feet	Rotate the tilt feet to adjust the projector's height.

INTRODUCTION

No.	Item	Function
5.	Lens	Images are projected from here.
6.	Ventilation (Outlet)	Heated air is exhausted from here.
7.	Input / Output	Connect the cables for the various audio and video signals.
8.	Security Slot (K)	This is used when attaching an anti-theft cable. TIP: <ul style="list-style-type: none"> Security and theft protection lock compatible with Kensington security cables/equipment. For products, visit Kensington's website.
9.	Security Bar	Attach an anti-theft device. The security bar accepts security wires or chains up to 0.18 inch/4.6 mm in diameter.
10.	Control Panel	Use the buttons to power the projector on/off and configure the projector settings. Refer to page 32 for more details.
11.	Main Power Switch	Turn on and off the power supply.
12.	AC Inlet	Connect the supplied power cord here, and plug the other end into an active wall outlet.
13.	Speaker	Emit sound.

Note:

- Do not block projector intake and exhaust vents.
- When operating the projector in an enclosed space, allow at least 1m (39.4") clearance around the intake and exhaust vents.

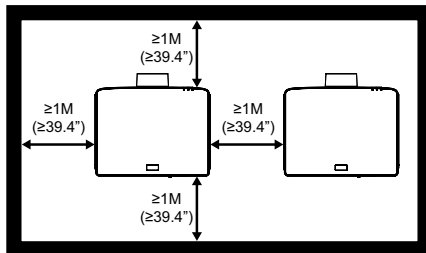

INTRODUCTION

- *Need to keep at least 15mm between the ceiling mount and bottom intake.*

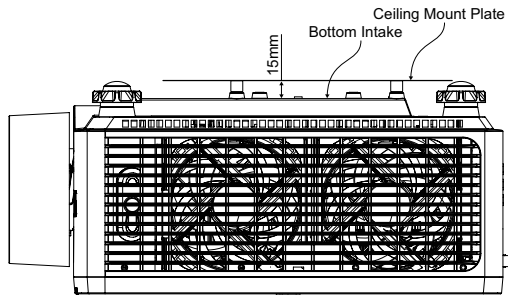

INTRODUCTION

Connections

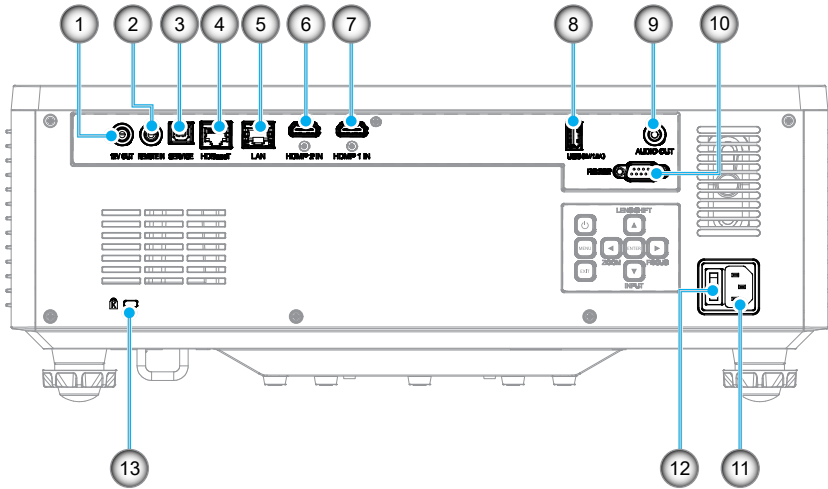

No.	Item
1.	12V Out Connector
2.	Remote In Connector (*1)
3.	USB Connector
4.	HDBaseT Connector
5.	LAN Connector
6.	HDMI 2 Connector
7.	HDMI 1 Connector

No.	Item
8.	USB Connector (Power 5V---1.5A) (*2)
9.	Audio Out Connector (*3)
10.	RS-232 Connector
11.	AC Inlet
12.	Main Power Switch
13.	Security Slot (R)

Note:

- *1 The system will automatically detect when a wired remote control is plugged in, and when a wired remote control is detected, the system will disable the reception and control of wireless remote control signals.
- *2 Not recommended for charging a cell phone.
- *3 Audio Out connector provides an audio signal output only if the projector is in the power-on state.

INTRODUCTION

Control Panel

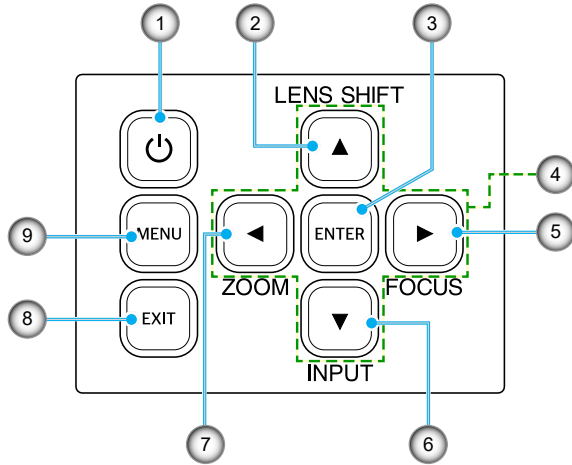

No.	Button	Function
1.	Power Button	Turns the projector on or off.
2.	Lens Shift	Adjust the lens vertical / horizontal position.
3.	Enter	Confirm the settings.
4.	Four Directional Select Keys	Navigation keys.
5.	Focus	Adjust the image focus.
6.	Input	Select the input signal port.
7.	Zoom	Adjust the image size.
8.	Exit	Returns to previous menu or exit menu if at top level.
9.	Menu	Shows the main menu on screen.

INTRODUCTION

Remote Control

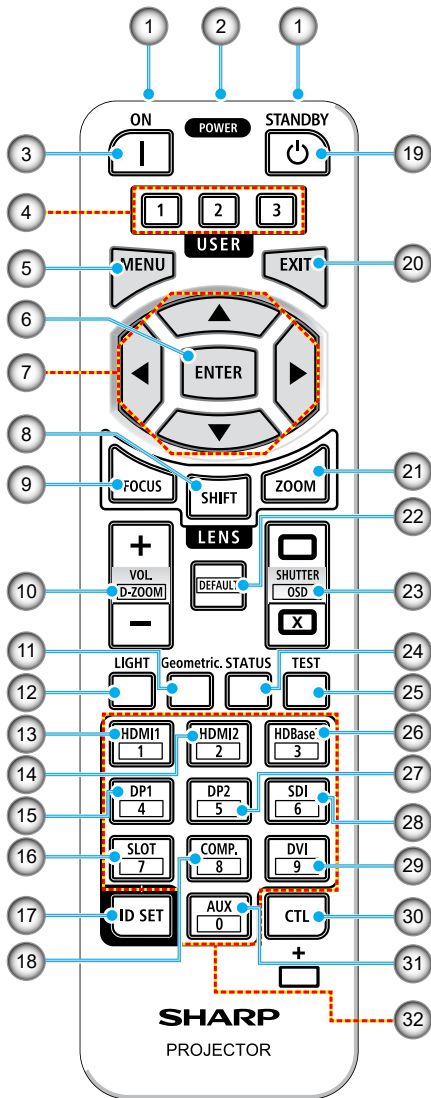

1. **Infrared Transmitter**
Remote control signals are sent via infrared signal. Point the remote control at the remote control receiver on the projector.
2. **Remote Jack**
Connect a commercially available remote cable here for wired operation.
3. **POWER ON Button (|)**
Turns power ON when in sleep or standby mode.
4. **USER 1/2/3 Button**
The following 9 functions can be selected and set. Available options are Color Mode, A/V Mute, Color Temperature, Orientation, Aspect Ratio, Freeze Screen, Network Setup, Audio Mute, and On Screen Display.
5. **MENU Button**
Displays the on-screen menu for various settings and adjustments.
6. **ENTER Button**
Moves to the next menu when the on-screen menu is displayed. Confirms the item when the confirmation message is displayed.
7. **▲▼◀▶ Button**
When the on-screen menu is displayed, use the ▲▼◀▶ buttons to select the item that you wish to set or adjust.
8. **SHIFT Button**
The lens shift adjustment screen will be displayed. Use the ▲▼◀▶ buttons to adjust the lens position.
9. **FOCUS Button**
Opens the focus adjustment screen. Adjust the focus (of the lens) with the ▲/▼ buttons.

INTRODUCTION

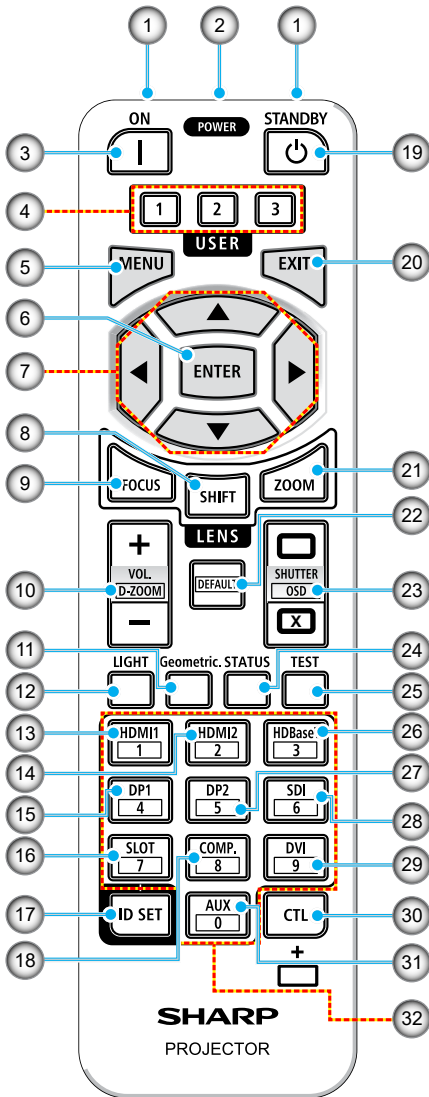

10. **VOL./D-ZOOM (+)(-) Button**
Adjusts the volume level of the audio output terminals. Simultaneously pressing the CTL button will expand or shrink the image (return to the original state).
11. **Geometric. Button**
Displays [Geometric Correction] from the on-screen menu. Use it to adjust distortions in projected images.
12. **LIGHT Button**
Displays the light mode screen.
13. **HDMI1 Button**
Selects the HDMI1 input.
14. **HDMI2 Button**
Selects the HDMI2 input.
15. **DP1 Button**
(Not available on this series of projectors.)
16. **SLOT Button**
(Not available on this series of projectors.)
17. **ID SET Button**
Used to set the control ID when performing individual operations on multiple projectors using the remote control.
18. **COMP. Button**
(Not available on this series of projectors.)
19. **POWER STANDBY Button (⏻)**
Pressing the button once will display the shutdown confirmation message. Press the POWER STANDBY button once more to power down the projector.

INTRODUCTION

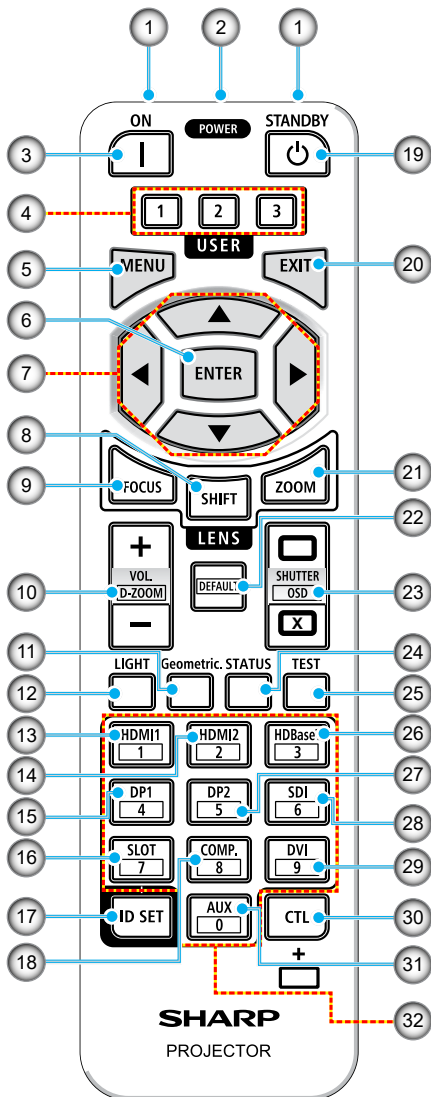

20. **EXIT Button**
Returns to the menu on the previous level when the on-screen menu is displayed. Closes the menu when a cursor appears in the main menu. Cancels the operation when the confirmation message is displayed.
21. **ZOOM Button**
Opens the zoom adjustment screen. Adjust zoom with the ▲/▼ buttons.
22. **DEFAULT Button**
(Not available on this series of projectors.)
23. **SHUTTER / OSD OPEN (□) / CLOSE (X) Button**
Press the CLOSE button to turn off the light source and temporarily stop projection. Press the OPEN button to resume. Simultaneously press the CTL and CLOSE buttons to close the on-screen display (On-Screen Mute). Simultaneously press the CTL and OPEN buttons to go back.
24. **STATUS Button**
Displays [Information] from the on-screen menu.
25. **TEST Button**
Projects a test pattern.
26. **HDBaseT Button**
Selects the HDBaseT input.
27. **DP2 Button**
(Not available on this series of projectors.)
28. **SDI Button**
(Not available on this series of projectors.)

INTRODUCTION

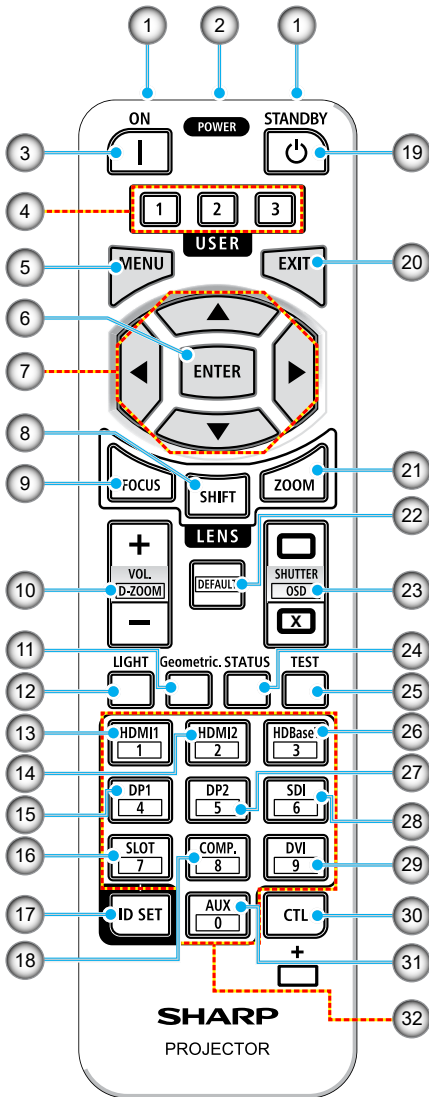

- 29. **DVI Button**
(Not available on this series of projectors.)
- 30. **CTL Button**
This is a multipurpose button for combined use with other buttons.
- 31. **AUX Button**
(Not available on this series of projectors.)
- 32. **Numeric Keypad Button**
Used to input the control ID when performing individual operations on multiple projectors using the remote control (set the control ID). Pressing the 0 button while holding down the ID SET button will remove any control ID settings.

SETUP AND INSTALLATION

Connecting Sources to the Projector

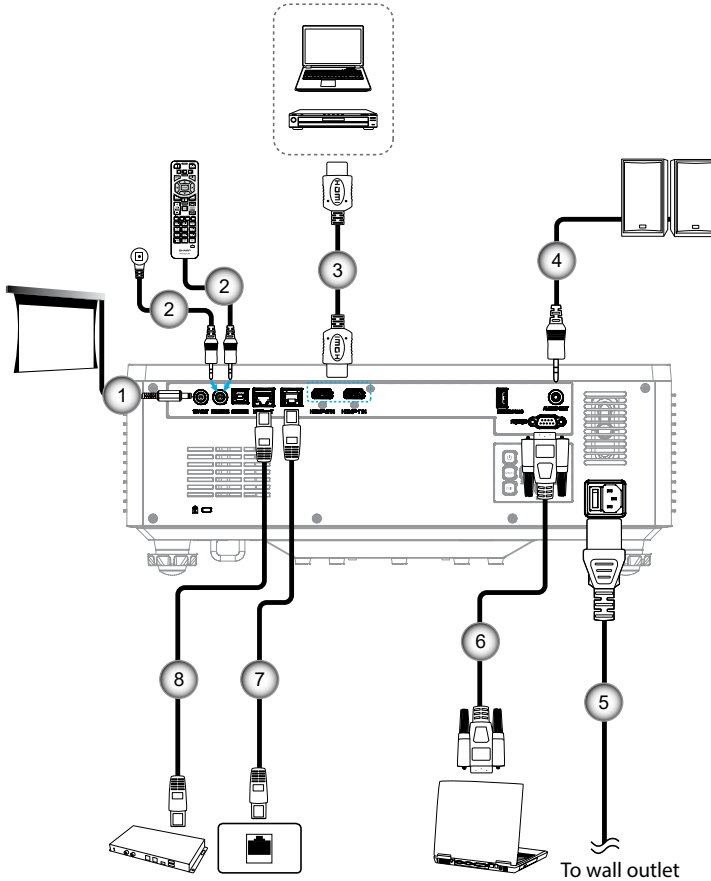

No.	Item
1.	12V DC Jack
2.	Wired Remote Control Cable or IR Receiver Cable (3.5mm TRS type)
3.	HDMI Cable
4.	Audio Out Cable

No.	Item
5.	Power Cord
6.	RS232C Cable (Cross Cable)
7.	RJ-45 Cable (Cat.5e)
8.	RJ-45 Cable (Cat.6A)

SETUP AND INSTALLATION

Adjusting the Projector Image

Adjusting the Projector's Height

The projector is equipped with elevator feet for adjusting the image height.

1. Locate the adjustable foot you wish to adjust on the underside of the projector.
2. Rotate the adjustable foot clockwise or counterclockwise to raise or lower the projector.

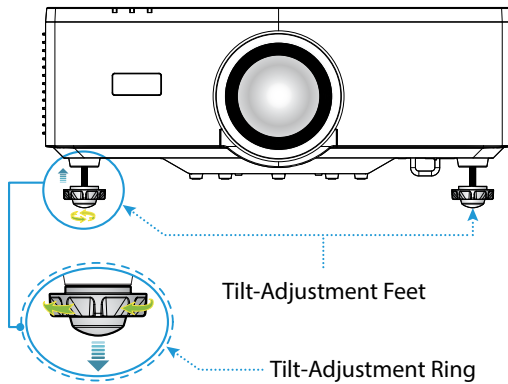

Note:

- Do not lengthen the tilt foot any more than 19 mm (0.75"). Doing so will make the projector unstable.
- Do not use the tilt foot for any purpose other than adjusting inclination of the projector installation angle. Handling the tilt foot improperly, such as carrying the projector by grasping the tilt foot or hooking it onto a wall using the tilt foot, could damage the projector.

SETUP AND INSTALLATION

Lens Shift Range

This device features a Motorized lens shift function that allows you to adjust the screen position using the Remote control or Control Panel on the back of the projector (see page 32). You can perform lens shift within the following range.

Lens Shift Range

Vertical Direction	Horizontal Direction
± 55%	± 25%

Note: If the lens shift exceeds the range shown in the diagram, the edges of the screen may appear blurry or exhibit shadows.

The symbols represent:

- V for vertical (height of the projected screen).
- H for horizontal (width of the projected screen). The lens shift range is expressed as a ratio of height and width.

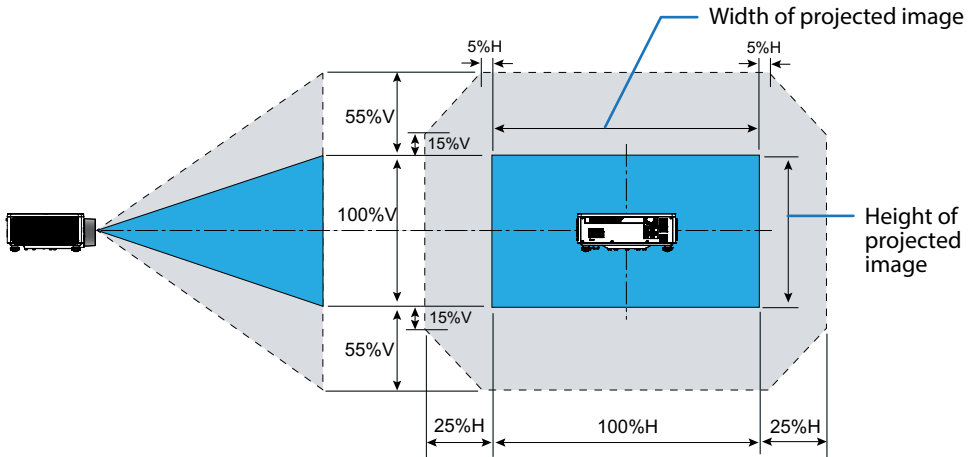

SETUP AND INSTALLATION

Calculation Example: When projecting with 150 inches

- According to the "Image Size and Projection Distance" (→ page 96), the screen dimensions are **H=332.1 cm** and **V=186.8 cm**.
- **Vertical Adjustment Range:** You can move the projection screen **upwards by approximately 103 cm** ($0.55 \times 186.8 \text{ cm} \approx 103 \text{ cm}$) and **downwards by approximately 103 cm**.
- **Horizontal Adjustment Range:** You can move the projection screen **leftwards by approximately 83 cm** ($0.25 \times 332.1 \text{ cm} \approx 83 \text{ cm}$) and **rightwards by approximately 83 cm**.

Note: *There may be a few percent error due to the simplified calculation formula.*

SETUP AND INSTALLATION

Adjusting the Projector's Zoom and Focus

Use the remote control or projector keypad to adjust the zoom and focus of the projected image.

- To adjust the image size, press **ZOOM** and the ▲/▼ buttons to get the required image size. (A)
- To adjust the image focus, press **FOCUS** and the ▲/▼ buttons until the image is sharp and legible. (B)

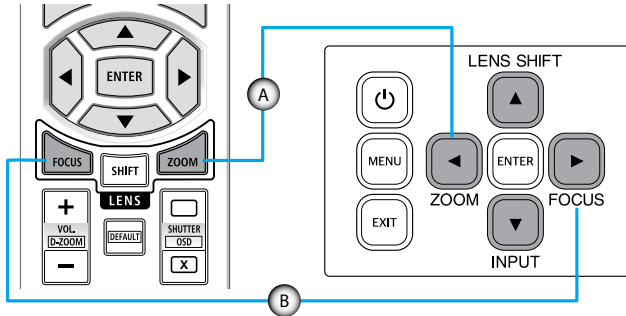

Note: Recommend to perform the focus adjustment after leaving the projector under the state the Test Pattern has been projected for over 30 minutes. Please refer to page 53 and 69 about the Test Pattern.

SETUP AND INSTALLATION

Adjusting the Projector Position

When you select a position for the projector, consider the size and shape of your screen, the location of your power outlets, and the distance between the projector and the rest of your equipment.

Follow these general guidelines:

- Position the projector on a flat surface at a right angle to the screen. The distance must be at least 64.6 inch (1.64 m) from the projection screen.
- Position the projector to the desired distance from the screen. The distance from the lens of the projector to the screen, the zoom setting, and the video format determine the size of the projected image.
- Lens throw ratio: 1.25 ~ 2.0
- 360 degrees free orientation operation.

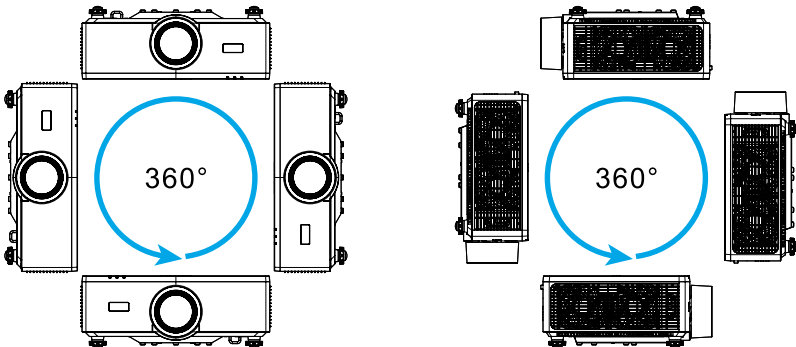

- When installing multiple projectors, keep at least 1m (39.4") space between the adjacent projectors.
- For ceiling/wall mount installations, make sure to leave 15 mm (0.6") between the ceiling mount and the bottom intake vents of the projector.

SETUP AND INSTALLATION

Remote Setup

Battery Installation

1. Press the catch and remove the battery cover.

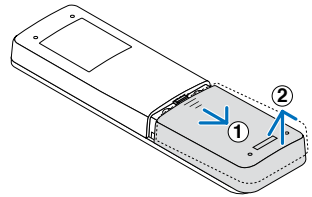

2. Install new ones (AAA manganese or alkaline batteries). Ensure that you have the batteries' polarity (+/-) aligned correctly.

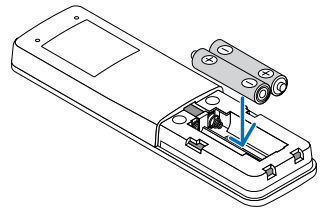

3. Slip the cover back over the batteries until it snaps into place.

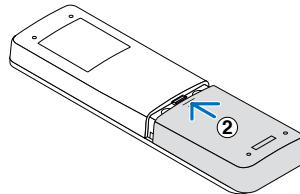
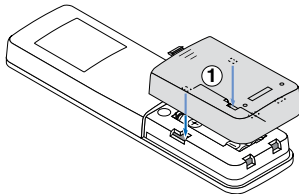

Note: Do not mix different types of batteries or new and old batteries.

Remote Control Precautions

- Handle the remote control carefully.
- If the remote control gets wet, wipe it dry immediately.
- Avoid excessive heat and humidity.
- Do not short, heat, or take apart batteries.
- Do not throw batteries into fire.
- If you will not be using the remote control for a long time, remove the batteries.
- Ensure that you have the batteries' polarity (+/-) aligned correctly.
- Do not use new and old batteries together, or use different types of batteries together.
- Dispose of used batteries according to your local regulations.
- Please note that if multiple projectors are installed nearby, other projectors may unintentionally light up when you turn on the power using the remote control.

SETUP AND INSTALLATION

Remote Control Effective Range

Infra-Red (IR) remote control sensor is located on the top and front of the projector. Ensure to hold the remote control at an angle within 30 degrees perpendicular to the projector's IR remote control sensor to function correctly. The distance between the remote control and the sensor should not be longer than 6 meters (19.7 feet) when holding not longer than 8 meters (26.3 feet) when aiming the sensor at 0°.

- Make sure that there are no obstacles between the remote control and the IR sensor on the projector that might obstruct the infra-red beam.
- Make sure the IR transmitter of the projector/remote control is not being shined by sunlight or fluorescent lamps directly.
- Please keep the remote controller away from fluorescent lamps for over 2 m or the remote controller might become malfunction.
- If the remote control is close to Inverter-Type fluorescent lamps, it might become ineffective from time to time.
- If the remote control and the projector are within a very short distance, the remote control might become ineffective.
- When you aim at the screen, the effective distance is less than 5 m from the remote control to the screen and reflecting the IR beams back to the projector. However, the effective range might change according to screens.

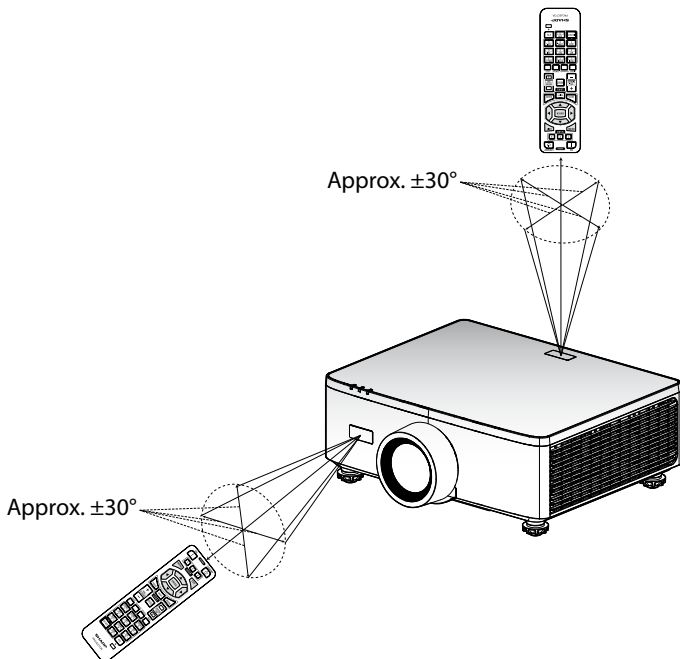

USING THE PROJECTOR

Powering On / Off the Projector

Powering On

1. Securely connect the power cord and signal/source cable.
2. Set the main power switch to the "I" (On) position and wait until the power LED becomes orange.

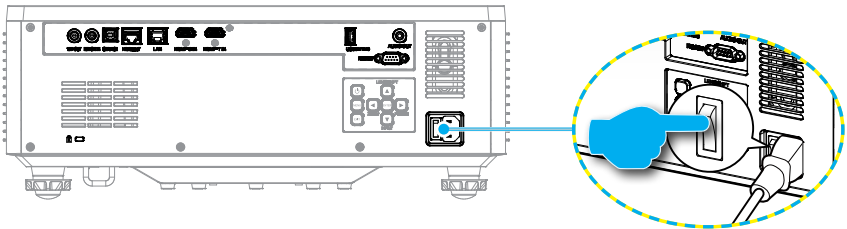

3. Turn on the projector by pressing the "⏻" button on the projector keypad or the POWER ON (I) button on the remote control.

During startup the power LED is flashing red and during normal operation, the power LED is solid green.

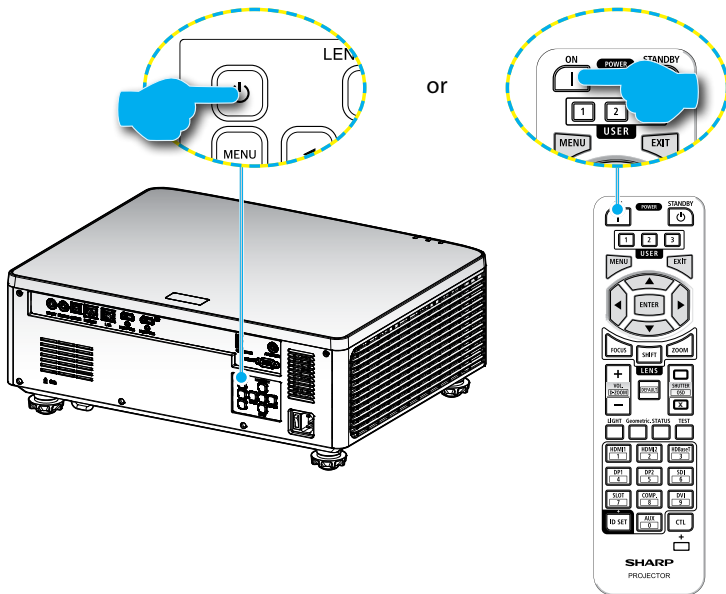

USING THE PROJECTOR

Powering Off

1. Turn off the projector by pressing the “⏻” button on the projector keypad or the POWER STANDBY (⏻) button on the remote control. The following message will be displayed:



2. Press the ⏻ or POWER STANDBY (⏻) button again to confirm, otherwise the message will disappear after 15 seconds. When you press the ⏻ or POWER STANDBY (⏻) button for the second time, the projector will shut down.
3. During the cooling cycle, the power LED is flashing green. When the power LED turns solid orange, this indicates the projector has entered standby mode. If you wish to turn the projector back on, you must wait until the cooling cycle has finished and the projector has entered standby mode. When the projector is in standby mode, simply press the “⏻” button on the projector or the POWER ON (⏻) button to turn on the projector.
4. Disconnect the power cord from the electrical outlet and the projector.

Note:

- *It is not recommended that the projector is turned on immediately, right after a power off procedure.*
- *By default, the projector turns off automatically after 20 minutes of inactivity. You can modify the idle time length in “Auto Power off (min)” menu in “System ⇒ Power Settings”. If you want the projector to enter standby mode instead, disable auto power off and set the sleep time interval in “System ⇒ Power Settings ⇒ Off Timer (min)”.*

USING THE PROJECTOR

Menu Navigation and Features

The projector has multilingual on-screen display (OSD) menus that allow you to make image adjustments and change a variety of settings.

1. To open the OSD menu, press the **MENU** key on the remote control or projector keypad.
2. To select a main menu or sub menu, use the **▲▼** buttons to highlight it. Then, press the **ENTER** button to enter the sub menu.
3. Press the **EXIT** button to return to the previous menu or exit the OSD menu if at top level.
4. Setting methods to adjust the function value or selection an option.
 - To adjust the slide bar values, highlight the function, and use the **◀▶** buttons to change value.
 - To check or uncheck a checkbox, highlight the function, and press **ENTER**.
 - To input a number or symbol, highlight the number or symbol, and use the **▲▼** buttons to make a selection. You can also use the number keys on the remote control or keypad.
 - To select a function option, use the **▲▼◀▶** buttons to make the selection. If no **ENTER** icon shows at the navigation bar, the highlighted option is automatically applied. If there is an **ENTER** icon at the navigation bar, press **ENTER** to confirm your selection.

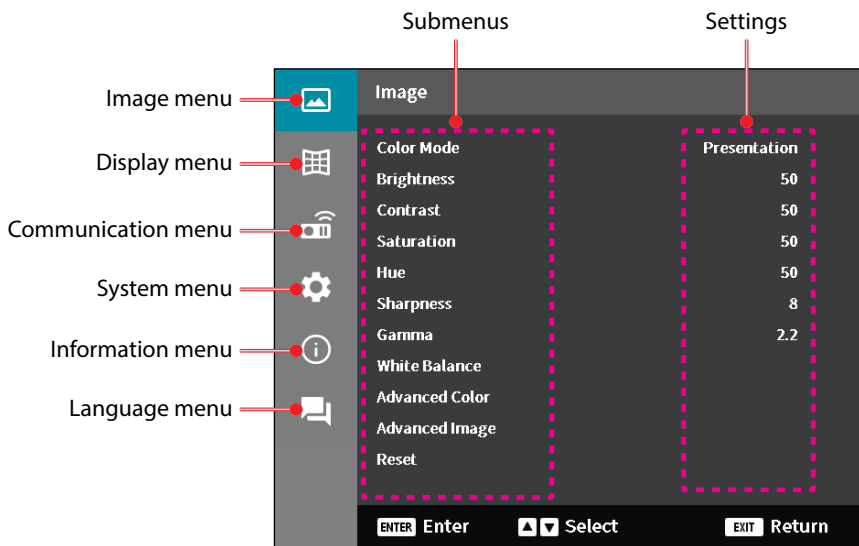

USING THE PROJECTOR

OSD Menu Tree

Main Menu	Sub Menu 2	Sub Menu 3	Sub Menu 4	Sub Menu 5	Option / Value	Default	
Image	Color Mode				Presentation	Color mode defaults depending on source. By Color Table Color Mode should reappplied to previous user setting after 3D is turned on and off. Always autosave image settings to each mode.	
					HDR		
					HLG		
					Cinema		
					sRGB		
					High Bright		
					DICOM SIM.		
					3D		
					High Frame Rate		
		Brightness			0 - 100	By Color Table	
		Contrast			0 - 100	By Color Table	
		Saturation			0 - 100	By Color Table	
		Hue			0 - 100	By Color Table	
		Sharpness			1 - 15	By Color Table	
		Gamma				Graphics	By Color Table
						1.8	
						2.0	
						2.2	
						2.4	
						3D	
						Blackboard	
						DICOM SIM.	
						HDR	
White Balance	Color Temperature				Warm	By Color Table	
					Standard		
					Cool		
		Red Gain			0 - 100	50	
		Green Gain			0 - 100	50	
		Blue Gain			0 - 100	50	
		Red Offset			0 - 100	50	
		Green Offset			0 - 100	50	
		Blue Offset			0 - 100	50	

USING THE PROJECTOR

Main Menu	Sub Menu 2	Sub Menu 3	Sub Menu 4	Sub Menu 5	Option / Value	Default	
Image	Advanced Color	Color Space			Auto	Auto	
					RGB(0~255)		
					RGB(16~235)		
					YUV		
		Wall Color			Off	Off	
					Blackboard		
					Light Yellow		
				Light Green			
				Light Blue			
	Color Correction	Color			Red	Red	
					Green		
					Blue		
					Cyan		
					Magenta		
					Yellow		
					White		
				Hue	0 - 254		By Color Table
				Saturation	0 - 254		By Color Table
				Luminance	0 - 254		By Color Table
		Reset	Yes / No (Dialog box)				
Advanced Image	Dynamic Contrast	Dynamic Black		Checkbox	Unchecked		
		Extreme Black		Checkbox	Unchecked		
	Dynamic Range	HDR			Off	Auto	
					Auto		
	3D Setup	3D Mode			0 - 10	By HDR/HLG source	
					Off	Auto	
	3D Format	3D Format			Auto	Auto	
					Auto		
					Frame Packing		
					SBS		
				Top and Bottom			
		Frame Sequential					

USING THE PROJECTOR

Main Menu	Sub Menu 2	Sub Menu 3	Sub Menu 4	Sub Menu 5	Option / Value	Default	
Image	Advanced Image	3D Setup	3D Sync Invert		Off	Off	
					On		
			Reset		Yes / No (Dialog box)		
		Reset			Yes / No (Dialog box)		
Display	Lens	Focus			Focus In / Out		
		Zoom			Zoom In / Out		
		Lens Shift			Up (icon)		
					Down (icon)		
					Left (icon)		
					Right (icon)		
		Lens Shift Memory	Save Memory			Memory 1 - Memory 5	
			Apply Memory			Memory 1 - Memory 5	
	Clear Memory				Yes / No (Dialog box)	No	
		Lens Shift Calibration			Yes / No (Dialog box)	No	
	Lens Lock				Off	Off	
					On		
			Reset			Yes / No (Dialog box)	
			Aspect Ratio			4:3	Auto
					16:9		
					21:9		
				Letter Box			
				Auto			
Scale	Digital Zoom			80 - 180	100		
	Image Shift	Horizontal			0 - 100	50	
		Vertical			0 - 100	50	

USING THE PROJECTOR

Main Menu	Sub Menu 2	Sub Menu 3	Sub Menu 4	Sub Menu 5	Option / Value	Default
Display	On Screen Display	Menu Position			Top Left	Center
					Top Right	
					Center	
		Menu Timer			Off	10s
				5s		
				10s		
				20s		
				30s		
			60s			
		Information Hide			Off	Off
			On			
Background				Blue	Blue	
				Black		
Input Signal Setting	Auto Signal			Off	On	
				On		
	Quick Resync			Off	On	
				On		
	Input Signal			HDMI 1	HDMI 1	
				HDMI 2		
				HDBaseT		
	EDID Settings	HDMI 1 EDID		1.4	2.0	
				2.0		
		HDMI 2 EDID		1.4	2.0	
			2.0			
HDBaseT EDID		1.4	2.0			
		2.0				
	Reset			Yes / No (Dialog box)		
Orientation	Ceiling			Auto	Auto	
				On		
				Off		
	Rear			Off	Off	
				On		

USING THE PROJECTOR

Main Menu	Sub Menu 2	Sub Menu 3	Sub Menu 4	Sub Menu 5	Option / Value	Default	
Display	Test Pattern				Off	Off	
					Green Grid		
					Magenta Grid		
					White Grid		
					White		
					Black		
					Red		
					Green		
					Blue		
					Yellow		
					Magenta		
					Cyan		
					ANSI Contrast 4x4		
					Color Bars		
					Focus		
	Reset				Yes / No (Dialog box)		
Communi- cation	Remote Setup	Remote Code			0 - 99	0	
		Remote Lock			Off	Off	
					1 - 9		
		Remote Sensor	Front			Off	On
						On	
			Top			Off	Off
					On		
		HDBaseT			Off	Off	
					On		
		User1				Color Mode	A/V Mute
						A/V Mute	
						Color Temperature	
						Orientation	
						Aspect Ratio	
						Freeze Screen	
				Network Setup			
				Audio Mute			
				On Screen Display			

USING THE PROJECTOR

Main Menu	Sub Menu 2	Sub Menu 3	Sub Menu 4	Sub Menu 5	Option / Value	Default			
Communi- cation	Remote Setup	User2			Color Mode	Freeze Screen			
					A/V Mute				
					Color Temperature				
					Orientation				
					Aspect Ratio				
					Freeze Screen				
					Network Setup				
					Audio Mute				
					On Screen Display				
					User3			Color Mode	Audio Mute
								A/V Mute	
								Color Temperature	
								Orientation	
								Aspect Ratio	
				Freeze Screen					
				Network Setup					
				Audio Mute					
				On Screen Display					
				RJ-45					
Network Setup	LAN Interface				HDBaseT	RJ-45			
					Connected				
					Disconnected				
					MAC Address		AA:BB:CC:DD:FF:EE		
					DHCP		Off	Off	
							On		
					IP Address		---,---,----,---	192.168.0.100	
					Subnet Mask		---,---,----,---	255.255.255.0	
					Gateway		---,---,----,---	192.168.0.51	
					DNS 1		---,---,----,---	0.0.0.0	
					DNS 2		---,---,----,---	0.0.0.0	
					Apply			Yes / No (Dialog box)	
					Reset			Yes / No (Dialog box)	

USING THE PROJECTOR

Main Menu	Sub Menu 2	Sub Menu 3	Sub Menu 4	Sub Menu 5	Option / Value	Default	
Communi- cation	Control	Crestron	_____		Off	On	
			_____		On		
		PJ Link	_____		Off	On	
			_____		On		
		AMX	_____		Off	On	
	_____			On			
	Baud Rate			_____		Off	On
				_____		On	
				_____		9600	
				_____		115200	
	Command Format			_____		A	A
				_____		B	
Reset			_____		Yes / No (Dialog box)		

System	Standby Mode			_____	Normal Standby	Normal Standby	
				_____	Network Standby		
				_____	Sleep		
	Power Settings	Direct Power			_____	Off	Off
					_____	On	
		Auto Power			_____	Off	Off
					_____	On	
		Auto Power Off (min)			_____	0, 2-180	20
	Off Timer (min)			_____	0-960	0	
	Light Source Setup	Light Mode			_____	Normal	Normal
					_____	Eco.	
					_____	Constant Brightness	
_____					Light Power Adjustment		
Brightness Level				_____	10% - 100%	100%	
Keypad LED Settings				_____	Off	On	
				_____	On		

USING THE PROJECTOR

Main Menu	Sub Menu 2	Sub Menu 3	Sub Menu 4	Sub Menu 5	Option / Value	Default	
System	Security	Security			Off	Off	
					On		
		Security Timer	Month		0 - 35	0	
			Day		0 - 29	0	
			Hour		0 - 23	0	
		Change Password					
		12V Trigger			Off	Off	
					On		
		High Altitude			Off	Off	
					On		
		Audio Settings	Volume		0 - 10	5	
			Mute			Off	Off
						On	
			Audio Output			Auto	Auto
						Internal Speaker	
		Reset		Yes / No (Dialog box)			
	User Data	Save All Settings		Memory 1 - Memory 5	Memory 1		
		Load All Settings		Memory 1 - Memory 5	Memory 1		
	Reset	Reset OSD		Yes / No (Dialog box)			
		Reset All		Yes / No (Dialog box)			
Information	Projector	Model Name					
		Serial Number					
	System Status	Standby Mode					
		Total Projector Hours					
		Light Source Hours					
		Ambient Temp.					
		System Temp.					

USING THE PROJECTOR

Main Menu	Sub Menu 2	Sub Menu 3	Sub Menu 4	Sub Menu 5	Option / Value	Default	
Information	Control	Remote Code					
		Crestron					
		PJ Link					
		AMX					
		HTTP					
	Communication	LAN Interface					
		MAC Address					
		Network Status					
		DHCP					
		IP Address					
		Subnet Mask					
		Gateway					
		DNS 1					
	Signal	DNS 2					
		Input Signal					
Resolution							
Signal Format							
Pixel Clock							
Horz Refresh							
Vert Refresh							
FW Version	Color Space						
	Main Version						
	F-MCU Version						
	A-MCU Version						
	LAN Version						
	Formatter Version						
	HDBaseT Version						

USING THE PROJECTOR

Main Menu	Sub Menu 2	Sub Menu 3	Sub Menu 4	Sub Menu 5	Option / Value	Default
Language					English	English
					German	
					French	
					Italian	
					Spanish	
					Swedish	
					Korean	
					Polish	
					Hungarian	
					Russian	
					Greek	
					Turkish	
					Portuguese	
					Arabic	
					Czech	
					T-Chinese	
					Norwegian	
				Dutch		
				Japanese		
				S-Chinese		
				Thai		

USING THE PROJECTOR

Image Menu

Learn how to configure image settings.

Submenus

- Color Mode
- Brightness
- Contrast
- Saturation
- Hue
- Sharpness
- Gamma
- White Balance
- Advanced Color
- Advanced Image
- Reset

Color Mode

There are several predefined display modes that you can choose from to suit your viewing preference. Each mode has been fine-tuned by our expert colour team to ensure superior colour performance for wide range of content.

Presentation

In this mode, the color saturation and brightness are well-balanced.

HDR / HLG

Decodes and displays High Dynamic Range (HDR) / Hybrid Log Gamma (HLG) content for the deepest blacks, brightest whites, and vivid cinematic color using REC.2020 color gamut. This mode will be automatically enabled if HDR/HLG is set to Auto (and HDR/HLG Content is sent to projector – 4K UHD Blu-ray, 1080p/4K UHD HDR/HLG Games, 4K UHD Streaming Video). While HDR/HLG mode is active, other display modes (Cinema, Reference, etc.) cannot be selected.

Cinema

Provides the best balance of detail and colors for watching movies.

sRGB

Standardized accurate color.

High Bright

This mode is suitable for environments where extra-high brightness is required, such as using the projector in well-lit rooms.

USING THE PROJECTOR

DICOM SIM.

This sets the settings to be similar to the DICOM standard used in the medical industry.

Note: *The [DICOM SIM.] option is for training/reference only and should not be used for actual diagnosis.*

3D

Optimized settings for watching 3D content.

Note: *To experience the 3D effect, you will need to have compatible DLP Link 3D glasses. See 3D section for more information.*

High Frame Rate

High Frame Rate (HFR) refers to higher frame rates than typical prior practice.

Note: *High Frame Rate mode only supports input with 1080p 120/240Hz timing and cannot be manually set. The system automatically detects and switches to this mode.*

Brightness

Adjust the luminous brightness of the projected image to adapt to different ambient light.

Contrast

Adjust the contrast ratio of the projected image. The contrast controls the degree of difference between the lightest and darkest parts of the image.

Saturation

Adjust the saturation of the selected color. The value indicates the color shifts from or towards the white in the center of the chromaticity diagram.

Hue

Adjust the color balance of red and green in video images.

Sharpness

Adjust the clarity of details in the projected image to make the image clearer and sharper.

USING THE PROJECTOR

Gamma

Select an appropriate gamma value to optimize the image conformance to different input sources.

Graphics

Best for projecting photos from PC input.

1.8 / 2.0 / 2.2 / 2.4 / 2.6

Select a preset gamma value to adjust the image performance. In general, the smaller the value, the brighter the dark areas of the image will become. The standard gamma value is 2.2.

3D

Best for playing 3D videos.

Blackboard

Best for projecting on to a blackboard.

DICOM SIM.

Best for projecting monochrome medical images, such as X-ray diagram.

HDR

Best for playing HDR videos.

White Balance

Adjust the white balance of the projected image via gain and offset. Gain and offset are individual controls for each RGB channels used to set greyscale.

Color Temperature

Adjust the color temperature of the projected image. The available options are Warm, Standard, or Cool.

Red / Green / Blue Gain

Adjust the color of the image's bright areas.

Red / Green / Blue Offset

Adjust the color of the image's dark areas.

Note:

- *When 3D or High Frame Rate mode is selected, the Color Temperature will be unavailable.*
- *When displaying a video with difference color space (such as YCbCr), the Red Gain/Green Gain/Blue Gain option will be unavailable.*

USING THE PROJECTOR

Advanced Color

Configure the color advanced settings of the projected image to improve the color performance.

Color Space

Select a color space that has been specifically tuned for the input signal. The available options are Auto (default), RGB (0 ~ 255), RGB (16 ~ 235), and YUV.

Wall Color

Set the wall color of the projector to achieve best color performance for a specific wall. The available options are Off, Blackboard, Light Yellow, Light Green, Light Blue, Pink, and Gray.

Color Correction

Change the color of a projected image by adjusting each color component in the image. The adjustable color includes Red, Green, Blue, Cyan, Yellow, and Magenta (R / G / B / C / Y / M).

- **Red / Green / Blue / Cyan / Magenta / Yellow:** Select a color for further adjustment.
 - **Hue:** Adjust the hue of the selected color. The value reflects the number of degrees of rotation around the chromaticity diagram from the original color. Increasing value indicates counterclockwise rotation, and decreasing value, clockwise rotation.
 - **Saturation:** Adjust the saturation of the selected color. The value indicates the color shifts from or towards the white in the center of the chromaticity diagram.
 - **Luminance:** Adjust the luminance of the selected color. Increase the value to brighten the image (add white to a color) or decrease the value to darken the image (add black to a color).
 - **Reset:** Reset the Red, Green, Blue, Cyan, Magenta, or Yellow color to factory default values.
- **White:** Adjust the white color performance via setting the Red, Green, and Blue values.
 - **Red / Green / Blue:** Adjust the red, green, and blue colors to optimize the white color performance.

USING THE PROJECTOR

Advanced Image

Configure other advanced settings of the projected image.

Dynamic Contrast

Set up the Dynamic Contrast to maximize the contrast for dark content.

- **Dynamic Black:** Enable this function to automatically adjust the contrast ratio for video sources. It improves the black level in dark scenes by reducing the light output.
- **Extreme Black:** Enable this function to automatically increase the contrast ratio by turning off the laser light when black image is detected. This function is only available for RGB signal format.

Note:

- *When Dynamic Black is turned on, the Extreme Black will be unavailable.*
- *When Extreme Black is turned on, the Dynamic Black will be unavailable.*

Dynamic Range

Configure the HDR (High Dynamic Range) setting and its effect when displaying video from 4K Blu-ray players and streaming devices.

- **HDR:** Enable or disable the HDR function.
 - **Off:** Turn off HDR Processing. When set to Off, the projector will NOT decode HDR content.
 - **Auto:** Auto detect HDR signal.
- **HDR Brightness:** Adjust the strength of HDR/HLG.

Note:

- *For HDR signal, the default value is 5.*
- *For HLG signal, the default value is 3.*

3D Setup

3D video file combines two slightly different images (frames) of the same scene representing the different views that the left and right eyes see. When these frames are displayed fast enough and viewed with 3D glasses synchronized with the left and right frames, the viewer's brain then assemble the separate images into a single 3D image. 3D Menu provides options to set up the 3D functions to correctly display 3D videos.

- **3D Mode:** Enable or disable the 3D mode.
 - **Off:** Select "Off" to turn off 3D mode.
 - **Auto:** Select "Auto" to turn on 3D mode.

USING THE PROJECTOR

- **3D Format:** Use this option to select the appropriate 3D format content.
 - **Auto:** When a 3D identification signal is detected, the 3D format is selected automatically.
 - **Frame Packing:** Display 3D signal in “Frame Packing” format.
 - **SBS (Side by Side):** Display 3D signal in “Side-by-Side” format.
 - **Top and Bottom:** Display 3D signal in “Top and Bottom” format.
 - **Frame Sequential:** Display 3D signal in “Frame Sequential” format.
- **3D Sync Invert:** Use this option to enable/disable the 3D sync invert function.
- **Reset:** Reset the function settings to factory default values

Note:

- *This projector is a 3D ready projector with DLP-Link 3D solution.*
- *Please ensure that 3D glasses are in use for DLP-Link 3D content before enjoying your video.*
- *This projector supports frame sequential (page-flip) 3D via HDMI1/HDMI2 ports.*
- *To enable 3D mode, the input frame rate should be set to 60Hz only, lower or higher frame rate is not supported.*
- *To reach the best performance, resolution 1920x1080 is recommended, please note that 4K (3840x2160) resolution is not supported in 3D mode.*
- *When 3D mode is selected, the Presentation, HDR, HLG, Cinema, sRGB, High Bright, DICOM SIM., High Frame Rate, User mode will be unavailable.*

Reset

Reset all the image settings to factory default values.

USING THE PROJECTOR

Display Menu

Learn how to configure the settings to properly project images according to your installation circumstances.

Submenus

- Lens
- Aspect Ratio
- Scale
- Geometric Correction
- On Screen Display
- Background
- Input Signal Setting
- Orientation
- Test Pattern
- Reset

Lens Settings

Configure the lens settings to adjust the image quality and position.

Focus

Use the ▲ and ▼ buttons to adjust the focus of the projected image.

Zoom

Use the ⊕ and ⊖ buttons to adjust the size of the projected image.

Lens Shift

Use the ▲, ▼, ◀, ▶ buttons to adjust the lens position to shift the projected area.

Lens Shift Memory

This projector can save up to five lens settings, which records the lens position.

- **Save Memory:** Select a record from 1 to 5 to save the current lens settings.
- **Apply Memory:** Select a record from 1 to 5 to apply the lens settings.
- **Clear Memory:** Clear the saved lens records.

Lens Shift Calibration

Calibrate the lens position to return it to the center.

Note:

- *Ensure that the lens shift calibration has been executed before performing the lens shift.*
- *Performing a lens shift calibration will clear the saved lens records.*
- *When the lens shift calibration is not completed, the lens shift memory will be unavailable.*

USING THE PROJECTOR

Lens Lock

Lock the lens to prevent the lens motors from moving, which disables all lens functions.

Note:

- *Enabling the Lens Lock function will display the lens lock icon (🔒) at the upper right corner of the screen.*
- *Focus, Zoom, Lens Shift, Lens Shift Calibration, and Lens Shift Memory will not be available when the Lens Lock function is enabled. An (🔒) icon appears at the upper right corner of the screen.*

Reset

Reset the lens settings to factory default values.

Aspect Ratio

Set the aspect ratio of the projected image. The available options are 4:3, 16:9, 21:9, Letter Box, or Auto. Select Auto to display the detected image size.

- **4:3:** This format is for 4:3 input sources.
- **16:9:** This format is for 16:9 input sources, like HDTV and DVD enhanced for Wide screen TV.
- **21:9:** This format is for 21:9 input source, like HDTV and DVD enhanced for Wide screen TV.
- **Letter Box:** To ensure that the letterbox signal is properly projected, it will be enlarged equally in both the vertical and horizontal directions.

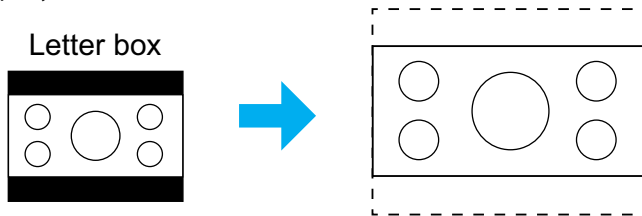

- **Auto:** Automatically selects the appropriate display format.

Scale

Digital Zoom

Use to reduce or magnify an image on the projection screen. Digital Zoom is not the same as optical zoom and can result in degradation of image quality.

Note: *Zoom settings are retained on power cycle of the projector.*

USING THE PROJECTOR

Image Shift

Adjust the projected image position.

- **Horizontal:** Use the ◀ and ▶ buttons to adjust the projected image position horizontally.
- **Vertical:** Use the ▲ and ▼ buttons to adjust the projected image position vertically.

Note: When the input signal is 2K resolution timing and 3D timing, image shifting will not be available.

Geometric Correction

Configure the geometric settings to reshape the image for different projection surfaces.

V Keystone

Adjust image distortion vertically and make a squarer image. Vertical keystone is used to correct a keystone image shape in which the top and bottom are slanted to one of the sides. This is intended when for use with vertically on-axis applications.

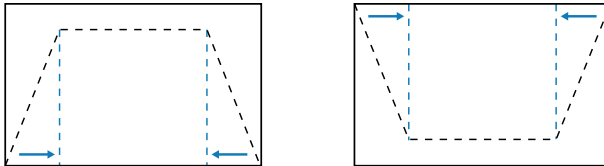

H Keystone

Adjust image distortion horizontally and make a squarer image. Horizontal keystone is used to correct a keystone image shape in which the left and right borders of the image are unequal in length. This is intended for use with vertically on-axis applications.

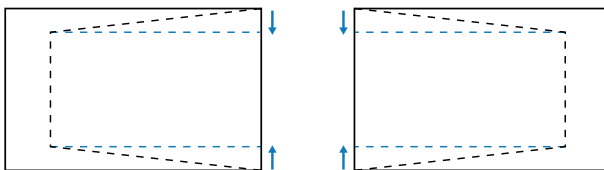

USING THE PROJECTOR

4-Corner

Reshape the image by moving the 4 corners of the image to have it fit a specific projection surface.

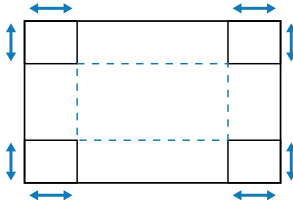

Warping

Enable or disable the application of warping adjustment effect.

Warping Adjustment

Use warping to adjust the image to align with the border of the projection surface (screen) or to eliminate image distortion (cause by an uneven surface).

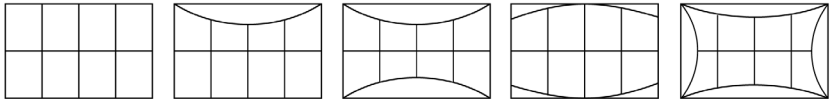

Grid Color

Select a grid color for warp between Green, Magenta, Red, and Cyan.

Reset

Reset geometric correction settings to factory default values.

On Screen Display

Menu Position

Select the menu location from Top Left, Top Right, and Center.

Menu Timer

Set the length of time the menu displays on the screen.

Information Hide

Enable or disable the corner information messages, such as input source, IP address, and so on.

USING THE PROJECTOR

Background

Set a background color to display when no input signal is detected. The available options are Blue and Black.

Input Signal Setting

Learn how to configure the projector input settings.

Auto Signal

When Auto Signal is enabled, the projector automatically detects and selects the input signal. Once an input source is selected, press the Input button on the remote control or keypad to switch to other available sources. When the function is disabled, pressing Input will bring up the Active Inputs submenu.

Quick Resync

When this function is enabled, auto signal detection will be faster.

Input Signal

Select an input signal from the source list. The available input sources are HDMI1, HDMI2, and HDBaseT.

EDID Settings

Switch EDID versions.

- **1.4:** Compatible with standard video signals.
- **2.0:** Supports 4K video signals. Set this when displaying 4K video using a device that supports 4K video.

Reset

Reset the signal settings to factory default values.

Orientation

Change the image direction by selecting a proper projection mode.

Ceiling

Enable the function for ceiling mount installation.

Rear

Check the function for rear projection.

Test Pattern

Select a test pattern. The available options are Off, Green Grid, Magenta Grid, White Grid, White, Black, Red, Green, Blue, Yellow, Magenta, Cyan, ANSI Contrast 4x4, Color Bars, and Focus.

USING THE PROJECTOR

Reset

Reset all the display settings to factory default values.

USING THE PROJECTOR

Communication Menu

Communication menu is used to configure the settings that allow the projector to communicate with other projectors or control devices.

Submenus

- Remote Setup
- Network Setup
- Control
- Baud Rate
- Command Format
- Reset

Remote Setup

Configure the settings of the Infra-Red (IR) remote control.

Remote Code

Setting the Remote Code can prevent interference from other identical remote controls. After adjusting this setting, you must also change the corresponding control ID on the remote control. Please refer to the ID SET button function description in item 17 on page 34.

Remote Lock

The IR receiving function of the projector can be temporarily deactivated by hot key (0 ~ 9) to avoid the IR interference between projectors. The remote ID needs to be set to All.

Note: *Enabling the Remote Lock function will display the remote lock icon  at the upper right corner of the screen.*

Remote Sensor

Set the remote receiver for the projector to control the communication between the projector and the IR remote.

- **Front:** Enable or disable the front remote receiver.
- **Top:** Enable or disable the top remote receiver.
- **HDBaseT:** Select On to set the HDBaseT terminal as the remote receiver.



Note:

- *Only one of the Front and Top IR receivers can be turned on or off at the same time.*
- *The system will automatically detect when a wired remote control is plugged in, and when a wired remote control is detected, the system will disable the reception and control of wireless remote control signals.*

USING THE PROJECTOR

User 1 / User 2 / User 3

Assign a function to the User 1, User 2, and User 3 buttons on the remote control. It allows you to use the function easily without going through the OSD menus. The available functions are Color Mode, A/V Mute, Color Temperature, Orientation, Aspect Ratio, Freeze Screen, Network Setup, Audio Mute, and On Screen Display.

Note: *When the Freeze and Audio Mute functions are enabled, the respective icon will appear at the upper right corner of the screen:
Freeze icon  / Audio Mute icon .*

Network Setup

Configure the projector's network settings.

LAN Interface

Specify the LAN interface to RJ-45 or HDBaseT.

Network Status

Display the network connection status. (Read only)

MAC Address

Display the MAC address. (Read only)

DHCP

Turn on DHCP to automatically acquire IP address, subnet mask, gateway, and DNS.

IP Address

Assign the projector's IP address.

Subnet Mask

Assign the projector's subnet mask.

Gateway

Assign the projector's gateway.

DNS 1/DNS 2

Assign the projector's DNS 1/DNS 2.

Apply

Apply the wired network settings.

Note: *If you have adjusted the settings of DHCP, IP Address, Subnet Mask, Gateway, DNS1/2, please be sure to execute "Apply" before the system will apply the settings to the network settings.*

Reset

Reset the network settings to default factory values.

USING THE PROJECTOR

Control

This projector can be controlled remotely by a computer or other external devices through wired network connection. It allows the user to control one or more projectors from a remote control center, such as powering the projector on or off, and adjusting the image brightness or contrast.

Use the Control submenu to select a control device for the projector.

Crestron

Control the projector with Crestron controller and related software (Port: 41794). For more information, please visit <https://www.crestron.com>.

PJLink

Control the projector with PJLink Class2 commands (Port: 4352). For more information, please visit <http://pjlink.jbmia.or.jp/english>.

AMX

Control the projector with AMX devices (Port: 9131). For more information, please visit <http://www.amx.com>.

HTTP

Control the projector with web browser (Port: 80). For more information, refer to "Overview of the web control panel" on page 76.

Baud Rate

Set the baud rate for Serial Port In and Serial Port Out. The available options are 9600, 19200, 38400, 57600, and 115200 (default).

Command Format

Switch between the available control commands. For the two supported control functions and commands, refer to the 'RS232 Protocol Function List' table on page 105.

Reset

Reset all control settings to default factory values.

USING THE PROJECTOR

Setup Network Control

LAN / RJ45 function

For simplicity and ease of operation, the projector provides diverse networking and remote management features.

The LAN / RJ45 function of the projector through a network, such as remotely manage: Power On / Off, brightness, and contrast settings.

HDBaseT function

Use a LAN cable sold commercially to connect the HDBaseT port of the projector to a HDBaseT transmission device sold commercially.

The HDBaseT port of the projector supports HDMI signals (HDCP) from transmission devices, control signals from external devices (serial, LAN) and remote control signals (IR commands).

Note: Refer to the owner's manual accompanied with your HDBaseT transmission for connecting with your external devices.

Connection examples of the wired LAN and HDBaseT

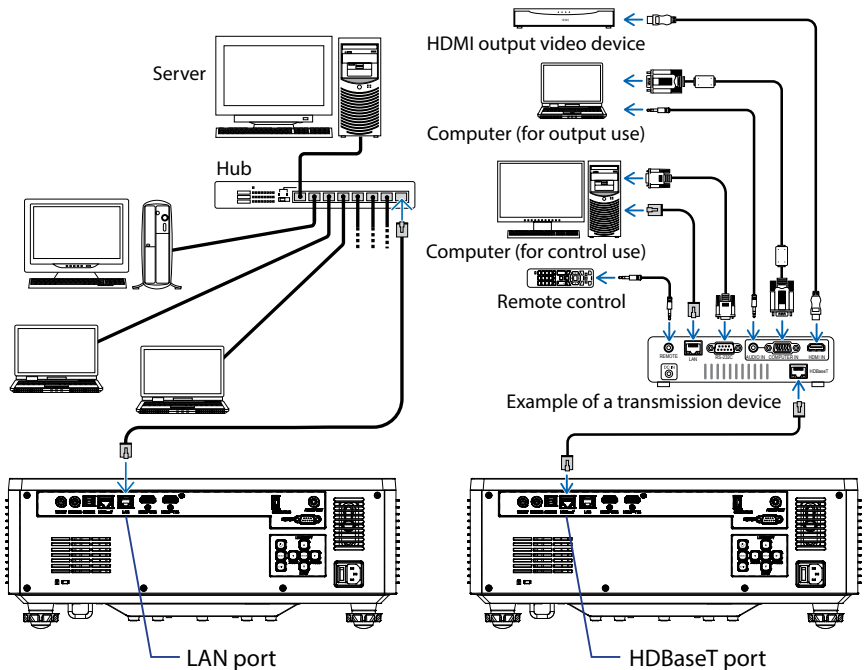

USING THE PROJECTOR

Wired LAN terminal functionalities

This projector can be controlled via the LAN port using a PC (laptop) or other external devices, supporting control functions such as NaViSet Administrator 2 / Web control / Crestron Connected V2 / AMX (Device-Discovery) / PJLink Class2.

Using the web control panel

The web control panel allows the user to configure various projector settings using a web browser from any personal computer or mobile devices.

System Requirements

To use the web control panel, make sure your devices and software meet the minimum system requirements

- RJ45 cable for HDBaseT port: CAT.6A
- RJ45 cable for LAN port: CAT.5e
- PC, laptop, mobile phone, or tablet installed with a web browser

USING THE PROJECTOR

Overview of the web control panel

Configure the projector settings using web browser.

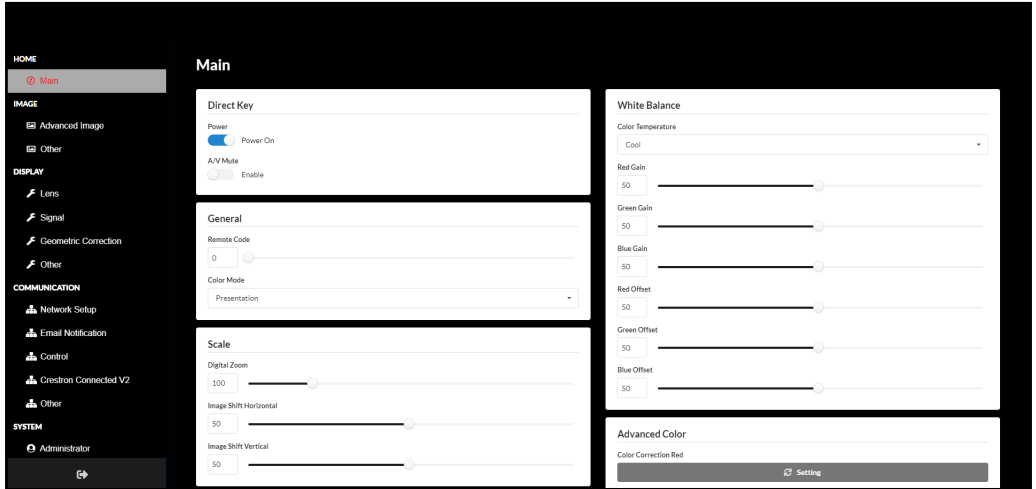

Menu	Description
HOME	View the projector information and firmware version details.
IMAGE	To configure image settings.
DISPLAY	To configure the settings to properly project images according to your installation circumstances.
COMMUNICATION	Communication menu is used to configure the settings that allow the projector to communicate with other projectors or control devices.
SYSTEM	To configure the system settings for the projector.
INFORMATION	View the projector information about its status and settings. The projector information is read only.
LANGUAGE	Set system display language.

USING THE PROJECTOR

Accessing the web control panel

When network is available, connect the projector and the computer to the same network. Use the projector address as the web URL to open the web control panel in a browser.

1. Check the projector address using the OSD menu.
 - Setup: **Communication** ⇒ **Network Setup** ⇒ **IP Address**.
2. Open a web browser and type the projector address in the address bar.
3. The web page redirects to the web control panel.
4. On first access, in the Username and Password fields, enter your username and password as follows:
 - Username: admin
 - Password: (Keep blank and no need to enter)

Note:

- *When logging in for the first time, you don't need to enter a password.*
- *It is needed to enter the own password once you have logged in. It is also advised to use a strong password.*
- *When you enter the password, pay enough attention to people around for the password abuse protection. If you have anxiety the password is cheated, change the password immediately.*

USING THE PROJECTOR

Date and Time

The projector can set the system date and time, and can automatically adjust the time through the NTP server.

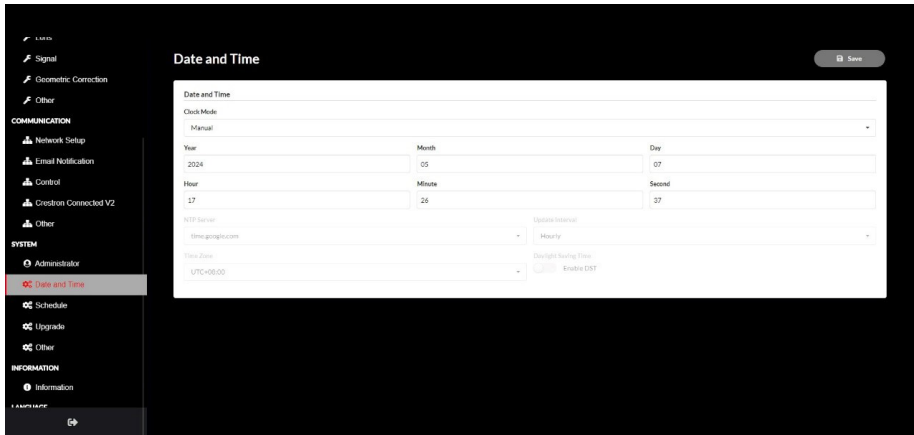

Clock Mode

You can choose to adjust the time manually or through the NTP server.

Manual

Manually set the system date and time. If “Manual” setting is enabled, only Year/ Month/Day/Hour/Minute/Second settings can be adjusted.

Use NTP Server

Correct the system date and time in the corresponding time zone through NTP Server. If “Use NTP Server” setting is enabled, only NTP Server/Update Interval/ Time Zone/Daylight Saving Time settings can be adjusted.

Year

Manually adjust year settings. The adjustment range is 2000 - 2037.

Month

Manually adjust month settings. The adjustment range is 1 - 12.

Day

Manually adjust day settings. The adjustment range is 1 - 31.

Hour

Manually adjust hour settings. The adjustment range is 00 - 23.

Minute

Manually adjust minute settings. The adjustment range is 00 - 59.

USING THE PROJECTOR

Second

Manually adjust second settings. The adjustment range is 00~59.

NTP Server

The system provides the following commonly used NTP servers to choose from:

1. time.google.com
2. asia.pool.ntp.org
3. europe.pool.ntp.org
4. north-america.pool.ntp.org

Update Interval

The interval at which the system automatically synchronizes time to the NTP server. Supports Hourly/Daily.

Time Zone

The system supports 38 time zone options from UTC+14 to UTC-12.

Daylight Saving Time

The daylight saving time setting can be enabled or disabled according to the needs of the area of use. When DST is enabled, the system will automatically adjust the time according to the selected time zone.

USING THE PROJECTOR

Schedule

The projector can be scheduled to perform repeated functions every day of the week.

The screenshot displays the 'Schedule' configuration page. On the left is a sidebar with navigation options: 'Status', 'Signal', 'Geometric Connection', 'Other', 'COMMUNICATION', 'Network Setup', 'Email Notification', 'Control', 'Connection Connected V2', and 'SYSTEM' (containing 'Administrator', 'Date and Time', 'Schedule', 'Logbooks', and 'Other'). The 'Schedule' option is highlighted in red. The main area is titled 'Schedule' and contains a 'Schedule View' section with a 'Schedule Mode' toggle (set to 'On') and a 'View Today' button. Below this is a 'View Schedule' button. The main content is a grid of seven daily schedule views: Monday, Tuesday, Wednesday, Thursday, Friday, Saturday, and Sunday. Each daily view has a 'Schedule Enable' toggle, a 'View Today' button, and a 'View Schedule' button. The grid shows a 3x3 layout for Monday-Friday, with Saturday and Sunday views below. Each daily view contains a list of scheduled events with columns for time, status, and name. For example, Tuesday shows events at 17:00 (Standby/Power On) and 17:11 (Power On). At the bottom of each daily view are 'Copy Events To' and 'Reset' buttons.

USING THE PROJECTOR

Schedule View

Display the current input signal of the projector.

Schedule Mode

Enable/Disable all scheduled events.

View Today

Display the current day of week.

Reset Schedule

Reset all scheduled events settings.

Monday – Sunday

Display list of scheduled events for day of week.

Schedule Enable

Enable/disable all scheduled events for the day.

Event 01 - 16

Supports up to 16 events per day.

Create Schedule

Create new event for day.

Hour

User can set 00 to 23 for hour.

Minute

User can set 00 to 59 for minute.

Function

Supports Power Settings / Input Source / Light Mode / A/V Mute of functions.

Event

Provides the following events based on user selection function:

1. Power Settings
 - i. Power On: Trigger projector power on.
 - ii. Standby (Normal Standby): Trigger the projector into standby and set the power setting to Normal Standby.
 - iii. Standby (Network Standby): Trigger the projector into standby and set the power setting to Network Standby.
 - iv. Standby (Sleep): Trigger the projector into standby and set the power setting to Sleep.

USING THE PROJECTOR

2. Input Source
 - i. HDMI 1: Trigger the projector to switch input source to HDMI 1 port.
 - ii. HDMI 2: Trigger the projector to switch input source to HDMI 2 port.
 - iii. HDBaseT: Trigger the projector to switch input source to HDBaseT port.
3. Light Mode
 - i. Normal: Trigger the projector and set the light mode to Normal.
 - ii. Eco.: Trigger the projector and set the light mode to Eco..
 - iii. Constant Brightness: Trigger the projector and set the light mode to Constant Brightness.
 - iv. Light Power Adjustment: Trigger the projector and set the light mode to Light Power Adjustment.
4. A/V Mute
 - i. A/V Mute On: Trigger the projector to mute Video and Audio.
 - ii. A/V Mute Off: Trigger the projector to disabled mute Video and Audio.

Copy Events To

Copy events scheduled throughout the day.

Current Day

Show today's week.

Copy To

Users can copy today's scheduled events to other days (Sunday to Saturday).

Reset

Reset scheduled events for the day.

USING THE PROJECTOR

System Menu

Learn how to configure the system settings for the projector.

Submenus

- Standby Mode
- Power Settings
- Light Source Setup
- Keypad LED Settings
- Security
- 12V Trigger
- High Altitude
- Audio Settings
- User Data
- Reset

Standby Mode

Setup the projector's standby mode.

Normal Standby

Minimum power consumption (0.5 Watt) which does not allow network control.

Network Standby

Low power consumption (< 2 Watt) which allows the LAN module to enter sleep mode and supports to be woken by Wake on LAN (WoL). When the LAN module is woken by WoL, the projector is ready to receive commands over the network.

Sleep

More power consumption that allows controlling the projector over the network.

Power Settings

Configure the projector's power settings.

Direct Power On

Choose "On" to activate Direct Power mode. The projector will automatically power on when AC power is supplied, without pressing the "Power" key on the projector keypad or on the remote control.

Auto Power On

Turn on this function to have the projector automatically turning on when connected to HDMI and HDBaseT input sources. It only applies to the standby projector set to Sleep.

USING THE PROJECTOR

Auto Power Off (min)

Set an interval timer for the projector to automatically turn off if no signal is detected within the specified time period. Press the ◀ and ▶ buttons to add or reduce time, 1 minutes for each press.

Off Timer (min)

Set an interval timer for the projector to automatically turn off after operating for the specified amount of time.

Note: *In the last minute before reaching a specified timer, including Auto Power Off, Off Timer, and Security Timer, an on-screen message will pop up warning that the projector shuts down in 60 seconds. Press any button on the remote control or projector keypad to reset the timer and the projector remains on.*

Light Source Settings

Adjust the energy saving settings and brightness matching between each projector when projecting multiple screens.

If you want to vary the brightness level at will, use “Constant Brightness” mode or “Light Power Adjustment” mode.

Light Mode

Select a light source mode depending on the installation requirements.

- Normal The Brightness Level is fixed at 100%.
- Eco. The Brightness Level is fixed at 50%.
 Brightness and fan control reduces noise and power consumption.
- Constant Brightness The brightness level is controlled to keep the brightness constant. The “Brightness Level” can be adjusted from 80% to 50%.
- Light Power Adjustment The image is projected at the brightness set by the Brightness Level. The Brightness Level can be adjusted from 100% to 10%.
 Power consumption decreases according to the Brightness Level, and the brightness changes depending on the time the projector is used.

Note: *“Constant Brightness” mode keeps the brightness constant. The color will not be constant.*

USING THE PROJECTOR

Brightness Level

Adjust the “Brightness Level” when the “Constant Brightness” and “Light Power Adjustment” are selected in Light Mode.

When you select “Normal” or “Eco,” you cannot select the “Brightness Level”.

Keypad LED Settings

Enable or disable the keypad LED.

Security

Set up security verification to protect the projector.

Security

Select On to protect the projector with a password. If the user enters incorrect password three times, a message will pop up warning that the projector shuts down in 10 seconds.

Security Timer

Specify the length of time the projector can be used without the password. Once the timer counts to 0, the user must enter a password to use the projector. The timer restarts every time the projector is turned on.

Change Password

Change the projector password.

12V Trigger

Use this function to enable or disable the trigger.

Note: 3.5mm TS type mini jack that outputs 12V 200mA (max.) for relay system control.

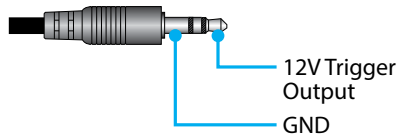

High Altitude

This unit has a built-in air pressure sensor, and the “High Altitude Mode” will automatically switch to “On” depending on the altitude of the installation location. When the High Altitude Mode is switched to On, the cooling fan will rotate at high speed.

If the High Altitude Mode does not switch to On even when the altitude exceeds 1500 m/5000 ft, manually switch “High Altitude” to “On”.

USING THE PROJECTOR

Audio Settings

Configure the projector built-in speaker settings.

Volume

Adjust the volume level.

Mute

Turn off or turn on the projector sound.

Note: *Enabling the Audio Mute function will display the mute icon  at the upper right corner of the screen.*

Audio Output

Select the audio output between Internal Speaker and Line Out.

Reset

Reset the audio settings to default factory values.

User Data

User can save the projector settings as user data and reload the settings later.

Save All Settings

Save all of the projector settings as user data. User can save up to 5 records.

Load All Settings

Load the previously saved user data.

USING THE PROJECTOR

Reset

Reset the settings to factory default values.

Reset OSD

Reset OSD settings to default values.

Reset All

Reset all projector settings to default values.

Reset table

Reset path	Category	System	
	SubCategory	Reset	
	SubSubCategory	Reset OSD	Reset All
Image	Color Mode	⊙	⊙
	Brightness	⊙	⊙
	Contrast	⊙	⊙
	Sharpness	⊙	⊙
	Gamma	⊙	⊙
	White Balance	⊙	⊙
	Color Space	⊙	⊙
	Wall Color	⊙	⊙
	Color Correction	⊙	⊙
	Dynamic Contrast	⊙	⊙
	Dynamic Range	⊙	⊙
3D Setup	⊙	⊙	
Display	Lens-Lens Shift Memory	⊙	⊙
	Lens-Lens Lock	⊙	⊙
	Aspect Ratio	⊙	⊙
	Scale	⊙	⊙
	On Screen Display	⊙	⊙
	Background	⊙	⊙
	Geometric Correction - V Keystone		⊙
	Geometric Correction - H Keystone		⊙
	Geometric Correction - 4-Corner		⊙
	Geometric Correction - Warping		⊙
	Geometric Correction - Grid Color		⊙
	Input Signal Setting	⊙	⊙
	Orientation	⊙	⊙
Freeze Screen	⊙	⊙	
Test Pattern	⊙	⊙	

USING THE PROJECTOR

Reset path	Category	System	
	SubCategory	Reset	
	SubSubCategory	Reset OSD	Reset All
Communication	Projector ID	⊙	⊙
	Remote Setup	⊙	⊙
	Network Setup		⊙
	Control		⊙
	Baud Rate	⊙	⊙
	Command Format	⊙	⊙
System	Standby Mode		⊙
	Power Settings	⊙	⊙
	Light Source Setup	⊙	⊙
	Keypad LED Settings	⊙	⊙
	Security		⊙
	12V Trigger	⊙	⊙
	Audio Settings	⊙	⊙
	User Data	⊙	⊙
Language		⊙	

USING THE PROJECTOR

Information Menu

View the projector information about its status and settings. The projector information is read only.

Submenus

- Projector
- System Status
- Control
- Communication
- Signal
- FW Version

Projector

Display the projector factory information.

Model Name

Display the projector model name.

Serial Number

Display the projector serial number.

System Status

Display the projector system status information.

Standby Mode

Display the current standby mode setting of the projector.

Total Projector Hours

Display the total projector usage hours.

Light Source Hours

Display the projector laser usage hours.

Ambient Temp.

Display the current ambient temperature of the projector.

System Temp.

Display the current system temperature of the projector.

USING THE PROJECTOR

Control

Display projector control setting information.

Remote Code

Display the current remote code setting of the projector.

Crestron

Display the current Crestron on or off setting of the projector.

PJLink

Display the current PJLink on or off setting of the projector.

AMX

Display the current AMX on or off setting of the projector..

HTTP

Display the current HTTP on or off setting of the projector.

Communication

Display the projector communication setting information.

LAN Interface

Display the current LAN interface settings of the projector.

MAC Address

Display the projector MAC address information.

Network Status

Display the projector network connection status.

DHCP

Display the projector DHCP settings.

IP Address

Display the current IP address of the projector.

Subnet Mask

Display the current Subnet Mask of the projector.

Gateway

Display the current Gateway of the projector.

DNS 1 / DNS 2

Display the current DNS1 and DNS2 address of the projector.

USING THE PROJECTOR

Signal

Display the projector input signal information.

Input Signal

Display the current input signal of the projector.

Resolution

Display the resolution of the current input signal source of the projector.

Signal Format

Display the format of the current input signal source of the projector.

Pixel Clock

Display the pixel clock of the projector's current input signal source.

Horz. Refresh

Display the horizontal refresh frequency of the projector's current input signal source.

Vert. Refresh

Display the vertical refresh frequency of the projector's current input signal source.

Color Space

Display the color space of the projector's current input signal source.

FW Version

Display the projector firmware version information.

Main / F-MCU / A-MCU / LAN / Formatter / HDBaseT Version

Display the projector firmware version information.

USING THE PROJECTOR

Language Menu

Learn how to select the language for the OSD (on-screen display) menu of the projector.

Submenus

- Language

Language

Select a language for the OSD menu. The available languages are English, German, French, Italian, Spanish, Swedish, Korean, Polish, Hungarian, Russian, Greek, Turkish, Portuguese, Arabic, Czech, Traditional Chinese, Norwegian, Dutch, Japanese, Simplified Chinese, and Thai.

ADDITIONAL INFORMATION

Compatible Resolutions

Horizontal : 15 - 255KHz

Vertical : 23 – 120Hz, 240Hz

Digital

Signal	Resolution (dots)	Aspect Ratio	Refresh Rate (Hz)	Note
VGA	640 x 480	4:3	60	
SVGA	800 x 600	4:3	60	
XGA	1024 x 768	4:3	60	
WXGA	1280 x 768	15:9	60	Only EDID1.4 support
WXGA	1280 x 800	16:10	60	
SXGA	1280 x 960	4:3	60	
SXGA	1280 x 1024	5:4	60	
FWXGA	1360 x 768	16:9	60	Only EDID1.4 support
FWXGA	1366 x 768	16:9	60	Only EDID1.4 support
WXGA+	1440 x 900	16:10	60	
HD+	1600 x 900	16:9	60	
UXGA	1600 x 1200	4:3	60	
WSXGA+	1680 x 1050	16:10	60	
WUXGA	1920 x 1200	16:10	60	Reduce Blanking
UWFHD	2560 x 1080	21:9	24/25/30/50/60	Only EDID 2.0 support
480P	720 x 480	4:3	60	
576p	720 x 576	5:4	50	
720p	1280 x 720	16:9	50/60/120	
1080p	1920 x 1080	16:9	24/25/30/50/60/ 120/240	Only EDID2.0 supports 1080P240
2160p	3840 x 2160	16:9	24/25/30/50/60	EDID1.4 supports up to 2160P 30Hz
4K2K	4096 x 2160	17:9	24/25/30/50/60	EDID1.4 supports up to 4K2K 24Hz

ADDITIONAL INFORMATION

3D

Signal	Resolution (dots)	Aspect Ratio	Refresh Rate (Hz)	Note
720p	1280 x 720	16:9	50/60	Top - and - Bottom
1080p	1920 x 1080	16:9	24/60	Top - and - Bottom
1080p	1920 x 1080	16:9	24/50/60	Side- by-Side (Half)
720p	1280 x 720	16:9	50/60	Frame packing
1080p	1920 x 1080	16:9	24	Frame packing
XGA	1024 x 768	4:3	120	Frame Sequential
720p	1280 x 720	16:9	120	Frame Sequential
1080p	1920 x 1080	16:9	60/120	Frame Sequential
WUXGA	1920 X 1200	16:10	60	Frame Sequential

ADDITIONAL INFORMATION

RS232 Port Setting and Signals Connection

RS232 Port Setting

Items	Method
Communication Method	Asynchronous Communication
Baud Rate	115200
Data Bits	8 bits
Parity	None
Stop Bits	1
Flow Control	None

RS232 Signals Connection

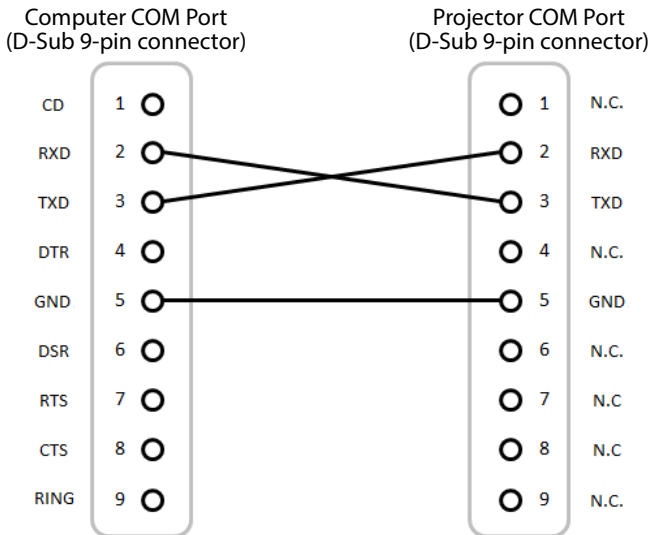

Note: RS232 shell is grounded.

ADDITIONAL INFORMATION

Image Size and Projection Distance

The size of projected images is 60 ~ 300 inches (1.64 ~ 13.35 m)

Screen Size 16:9 (Wx H)						Projector Distance			
Diagonal Length of Image		Width		Height		Wide		Tele	
inch	m	inch	m	inch	m	inch	m	inch	m
60	1.52	52.3	1.33	29.4	0.75	64.6	1.64	103.5	2.63
70	1.78	61.0	1.55	34.3	0.87	75.7	1.92	121.1	3.08
80	2.03	69.7	1.77	39.2	1.00	86.8	2.20	138.7	3.52
90	2.29	78.4	1.99	44.1	1.12	97.9	2.49	156.3	3.97
100	2.54	87.2	2.21	49.0	1.25	109.0	2.77	173.9	4.42
120	3.05	104.6	2.66	58.8	1.49	131.2	3.33	209.1	5.31
150	3.81	130.7	3.32	73.5	1.87	164.5	4.18	261.8	6.65
180	4.57	156.9	3.98	88.2	2.24	197.8	5.03	314.6	7.99
200	5.08	174.3	4.43	98.0	2.49	220.0	5.59	349.8	8.88
250	6.35	217.9	5.53	122.5	3.11	275.6	7.00	437.7	11.12
300	7.62	261.5	6.64	147.1	3.74	331.1	8.41	525.7	13.35

ADDITIONAL INFORMATION

Ceiling Mount Installation

1. To prevent damage to your projector, please use ceiling mount.
2. If you wish to use a third party ceiling mount kit, please ensure the screws used to attach a mount to the projector meet the following specifications:
 - Screw type: M4*4
 - Minimum screw length: 8 mm

Note: *The minimum length of the screw is 8mm, excluding the thickness of the ceiling mount.*

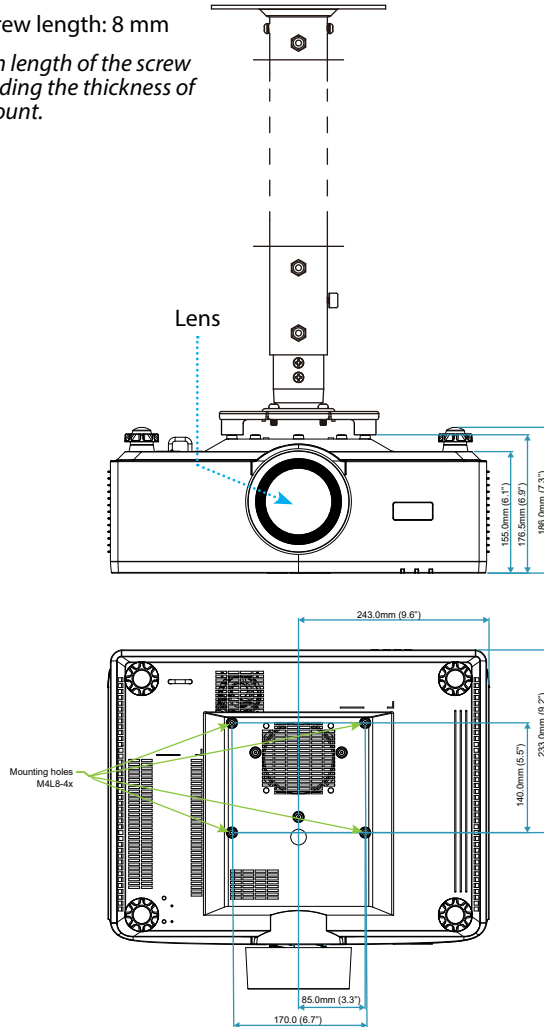

ADDITIONAL INFORMATION

External Dimensions

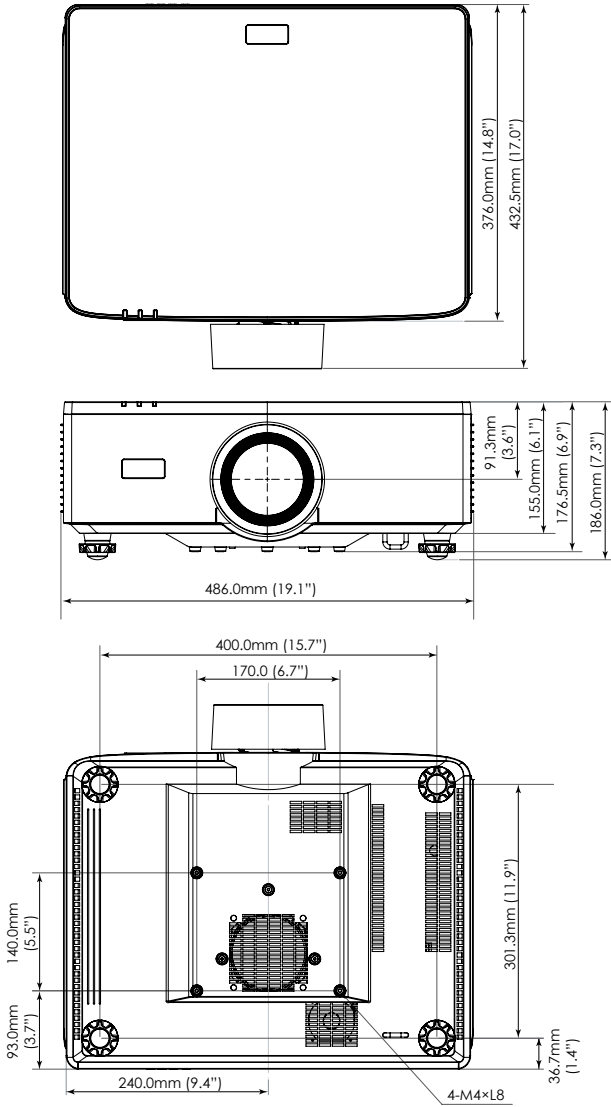

ADDITIONAL INFORMATION

Troubleshooting

If you experience a problem with your projector, please refer to the following information. If a problem persists, please contact your local reseller or service center.

Image problems

 *No image appears on-screen*

- Ensure all the cables and power connections are correctly and securely connected as described in the *Setup and Installation* section.
- Ensure the pins of connectors are not crooked or broken.
- Ensure that the Shutter feature is not turned on.

 *Image is out of focus*

- Press the **FOCUS** button on the remote control or projector keypad. Then press the **▲** or **▼** button to adjust the focus until the image is sharp and legible.
- Make sure the projection screen is between the required distance from the projector. (Please refer to *Image size and projection distance* page 96).

 *The image is stretched when displaying 16:9 DVD title*

- When you play anamorphic DVD or 16:10 DVD, the projector will show the best image in 16:9 format on projector side.
- If you play 4:3 format DVD title, please change the format as 4:3 in projector OSD.
- Please setup the display format as 16:9 (wide) aspect ratio type on your DVD player.

 *Image is too small or too large*

- Press the **ZOOM** button on the remote control or projector keypad . Then press the **▲** or **▼** button to adjust the projected image size.
- Move the projector closer to or further from the screen.
- From the OSD menu, select **Display** ⇒ **Aspect Ratio** to change the aspect ratio.

 *Image has slanted sides:*

- If possible, reposition the projector so that it is centered on the screen and below the bottom of the screen.
- Press the **Geometric.** buttons on the remote control to adjust distortions in projected images.

 *Image is reversed*

- From the OSD menu, select **Display** ⇒ **Orientation** ⇒ **Rear** to reverse the image so you can project from behind a translucent screen.

ADDITIONAL INFORMATION

Other problems

 *The projector stops responding to all controls*

- If possible, turn off the projector, then unplug the power cord and wait at least 20 seconds before reconnecting power.

Remote control problems

 *If the remote control does not work*

- Check that the operating angle of the remote control is pointed within $\pm 30^\circ$ to the IR receivers on the projector.
- Make sure there are not any obstructions between the remote control and the projector. Move to within 6 meters (19.7 feet) of the projector.
- Make sure batteries are inserted correctly.
- Replace batteries if they are exhausted.

ADDITIONAL INFORMATION

LED Indicators and Lightning Messages

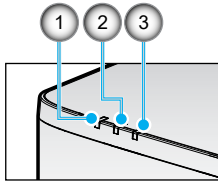

No.	Item
1.	TEMP. LED
2.	POWER LED
3.	STATUS LED

Status Light Color	STATUS LED	POWER LED			TEMP. LED	Note
	Red	Red	Green	Orange	Red	
STANDBY	-	-	-	ON	-	-
POWER ON	-	-	ON	-	-	-
WARMING UP STATE	-	FLASH	-	-	-	-
COOLING DOWN STATE	-	-	FLASH FAST	-	-	-
AV Mute / Shutter	FLASH	-	ON	-	-	-
ERROR STATUS						Recovery
POWER NG Error (Power Failure)	ON	-	-	-	ON	Repair
FAN LOCK	-	-	-	-	FLASH SLOW	Repair
WHEEL SPEED ERROR	-	-	-	-	FLASH	Repair
OVER HEAT					ON	Reboot
LD OVERHEAT					ON	Reboot
DMD OVER TEMPERATURE					ON	Reboot
WARNING STATUS						Recovery
DIM POWER	-	-	-	-	FLASH FAST	Reboot or Ambient Temp Cool Down
DMD PROTECTION MODE	FLASH FAST	-	-	-	FLASH FAST	Reboot or Ambient Temp Cool Down

Note:

- FLASH means 1s; FLASH_FAST means 500ms; FLASH_SLOW means 3s.
- **Repair** means the device needs to be repaired and the AC power cord has to be unplugged from the device.
- **Reboot** means Re-press the "power on" button on the remote control.
- DIM Power (Diminish Power)
- DMD PROTECTION MODE: Brightness dim to Eco. Mode.

ADDITIONAL INFORMATION

Specifications

This section provides technical information about projector's performance.

Projector

Model name		XP-P721Q-W	XP-P601Q-W
Method		1 Chip DLP type	
Resolution		4K UHD (3840 dots x 2160 lines)	
Specifications of main parts			
DMD panel	Size	0.65" (aspect ratio: 16:9)	
	Pixels (*1)	2,073,600 (1920 dots x 1080 lines)	
Projection lenses		F=2.0-2.4 / f=18.7~29.6 mm	
	Zoom	Motorized	
	Focus	Motorized	
	Lens shifting	Motorized	
Light source		Laser diode	
Light output (*2) (*3)		7200 lm	6000 lm
Screen size (throw distance)		60 to 300 inches (1.6 - 13.4 m)	
Color reproducibility		10-bit color processing (approx. 1.07 billion colors)	
Scanning frequency			
	Horizontal	15KHz to 255KHz	
	Vertical	24Hz to 85Hz, 120Hz for 2D/3D, 240Hz for 2D	
Input/output terminals			
HDMI 1/2	Video input	Type A x 2, Deep Color, LipSync, HDCP (*4), 4K	
	Audio input	Sampling frequency: 32/44.1/48 kHz Sampling bits: 16/20/24 bit	
HDBaseT	Video input	RJ-45 x 1, Deep Color, LipSync, HDCP (*4), 4K	
	Audio input	Sampling frequency: 32/44.1/48 kHz Sampling bits: 16/20/24 bit	
AUDIO OUT		Stereo mini jack x 1	
USB		USB type A x 1, 5.0 V/1.5 A power supply	
SERVICE		USB type B x 1	

ADDITIONAL INFORMATION

Model name		XP-P721Q-W	XP-P601Q-W
Control Terminals			
	LAN	RJ-45 x 1, 10BASE-T/100BASE-TX	
	RS232	D-Sub 9-pin x 1, RS232C	
	REMOTE IN	Stereo mini jack x 1	
	12V OUT	Stereo mini jack x 1	
Built-in Speaker		10 W x 2	
Usage environment		Operating temperature: 0 to 45°C / 32 to 113°F Operating humidity: 10 to 85% (with no condensation)	
		Storage temperature: -10 to 60°C / 14 to 140°F Storage humidity: 20 to 90% (with no condensation)	
		Operating altitude: 0 to 3048m / 0 to 10000 feet (1524 to 3048 m / 5000 to 10000 feet: Set [High Altitude] to [On])	
		0 to 762m / 0~2,500 ft.: 0°C~45°C 762 to 1524m / 2,500~5,000 ft.: for 0°C~35°C 1524 to 3048m / 5,000~10,000 ft.: for 0°C~30°C	
Power supply		100-240 VAC, 50/60 Hz	
Power consumption		530 W (100 - 120 V) / 520 W (200 - 240 V)	
Power consumption (Standby state)			
	Network enabled	less than 2.0 W (100–120 V) / less than 2.0 W (200–240 V)	
	Network disabled	less than 0.5 W (100–120 V) / less than 0.5 W (200–240 V)	
Rated input current		6.5 A (100–120 V) – 2.6 A (200–240 V)	
Power cord specification		10 A or higher	
External dimensions		19.1" (width) x 7.3" (height) x 17.0" (depth) / 486 (width) x 186 (height) x 432.5 (depth) mm (including protrusions)	
		19.1" (width) x 6.9" (height) x 17.0" (depth) / 486 (width) x 176.5 (height) x 432.5 (depth) mm (not including protrusions)	
Weight		32.4 lbs / 14.7 kg	

ADDITIONAL INFORMATION

Note:

- ***1** Effective pixels are more than 99.99%.
- ***2** Compliance with ISO 21118-2020.
- ***3** This is the light output value (lumens) when [Color Mode] is set to [High Bright] and [Light Mode] is set to [Normal]. If any other mode is selected, the light output value may drop slightly.
- ***4** If you are unable to view material via the HDMI and HDBaseT input, this does not necessarily mean the projector is not functioning properly. With the implementation of HDCP, there may be cases in which certain content is protected with HDCP and might not be displayed due to the decision/intention of the HDCP community (Digital Content Protection, LLC).
 - Video: Deep Color, 8/10/12-bit, Lip Sync.
 - Audio: LPCM: up to 2 ch, sample rate 32/44.1/48 KHz, sample bit; 16/20/24-bit
 - Version: HDMI: Supports HDCP 2.2
 - HDBaseT: Supports HDCP 2.2
- These specifications and the product's design are subject to change without notice.

For additional information, visit:

US: <https://www.sharpnecdisplays.us>

Europe: <https://www.sharpnecdisplays.eu>

Global: <https://www.sharp-nec-displays.com/global/>

ADDITIONAL INFORMATION

RS232 Protocol Function List

Command Format - A

Function	Code Data							
POWER ON	02H	00H	00H	00H	00H	02H		
POWER OFF	02H	01H	00H	00H	00H	03H		
INPUT SELECT HDMI 1	02H	03H	00H	00H	02H	01H	A1H	A9H
INPUT SELECT HDMI 2	02H	03H	00H	00H	02H	01H	A2H	AAH
INPUT SELECT HDBaseT	02H	03H	00H	00H	02H	01H	BFH	C7H

Command Format - B

Function	Code Data							
POWER ON	P	O	W	R	(SP)	(SP)	(SP)	1
POWER OFF	P	O	W	R	(SP)	(SP)	(SP)	0
INPUT SELECT HDMI 1	I	R	G	B	(SP)	(SP)	3	1
INPUT SELECT HDMI 2	I	R	G	B	(SP)	(SP)	3	2
INPUT SELECT HDBaseT	I	N	E	T	(SP)	(SP)	5	1
AV MUTE OFF	I	M	B	K	(SP)	(SP)	(SP)	0
AV MUTE ON	I	M	B	K	(SP)	(SP)	(SP)	1
AUDIO MUTE OFF	M	U	T	E	(SP)	(SP)	(SP)	0
AUDIO MUTE ON	M	U	T	E	(SP)	(SP)	(SP)	1

Note: (SP) in Parameter area means "space(20h)" in ASCII code.

ADDITIONAL INFORMATION

REGISTER YOUR PROJECTOR! (for residents in the United States and Mexico)

Please take time to register your new projector. This will activate your limited parts and labor warranty and InstaCare service program.

Visit our web site at <https://www.sharpnecdisplays.us/product-registration> and submit your completed form online.

Upon receipt, we will send a confirmation letter with all the details you will need to take advantage of fast, reliable warranty and service programs from the industry leader, Sharp Imaging and Information Company of America.

SHARP