



**THE BEST SUPPORT  
FOR YOUR AV & IT HARDWARE**  
T: + 31(0)23-5478888 | E: info@newstar.eu | W: www.newstar.eu

## LED-W700SILVER

## NEWSTAR FLAT SCREEN WALL MOUNT

Newstar TV/Monitor Wall Mount (Full Motion) for 32"-60" Screen - Silver



### SPECIFICATIONS

<b>Color</b>	Silver
<b>Distance to wall</b>	5 - 52 cm
<b>Height adjustment</b>	None
<b>Max. screen size</b>	60
<b>Max. weight</b>	35
<b>Min. screen size</b>	32
<b>Min. weight</b>	0
<b>Screens</b>	1
<b>Swivel (degrees)</b>	180°
<b>Tilt (degrees)</b>	17°
<b>Type</b>	Full motion Tilt Swivel
<b>VESA maximum</b>	600x400 mm
<b>VESA minimum</b>	200x200 mm
<b>VESA pattern</b>	200x200 200x300 200x400 300x200 300x300 350x350 400x400 400x300 400x600 440x400 500x400 600x200 600x300 600x400
<b>Warranty</b>	5 year
<b>EAN code</b>	8717371444518

The NewStar wall mount, model LED-W700SILVER is a full swing tilt- and swivel wall mount for flat screens up to 60" (152 cm). This mount is a great choice when you want the ultimate viewing flexibility with your flat screen TV. Effortless pull the display out from the wall, position it in almost any direction, turn it around corners and then smoothly return it to the wall when finished.

NewStars' tilt (17°) and swivel (180°) technology allows the mount to change to any viewing angle to fully benefit from the capabilities of the flat screen. The mount is easily depth adjustable from 5 to 52 centimetres. An innovative cable management conceals and routes cables from mount to flat screen. Hide your cables to keep living room, bedroom or home cinema installation nice and tidy.

NewStar LED-W700SILVER has three pivot points and is suitable for screens up to 60" (152 cm). The weight capacity of this product is 35 kg each screen. The wall mount is suitable for screens that meet VESA hole pattern 200x200 to 600x400mm. Different hole patterns can be covered using NewStar VESA adapter plates.

Create a clean design ambiance for your flat screen TV in the living room, bedroom or home cinema.

All installation material is included with the product.



THE BEST SUPPORT  
FOR YOUR AV & IT HARDWARE  
T: +31(0)23-5478888 | E: info@newstar.eu | W: www.newstar.eu

# LED-W700SILVER

# NEWSTAR FLAT SCREEN WALL MOUNT

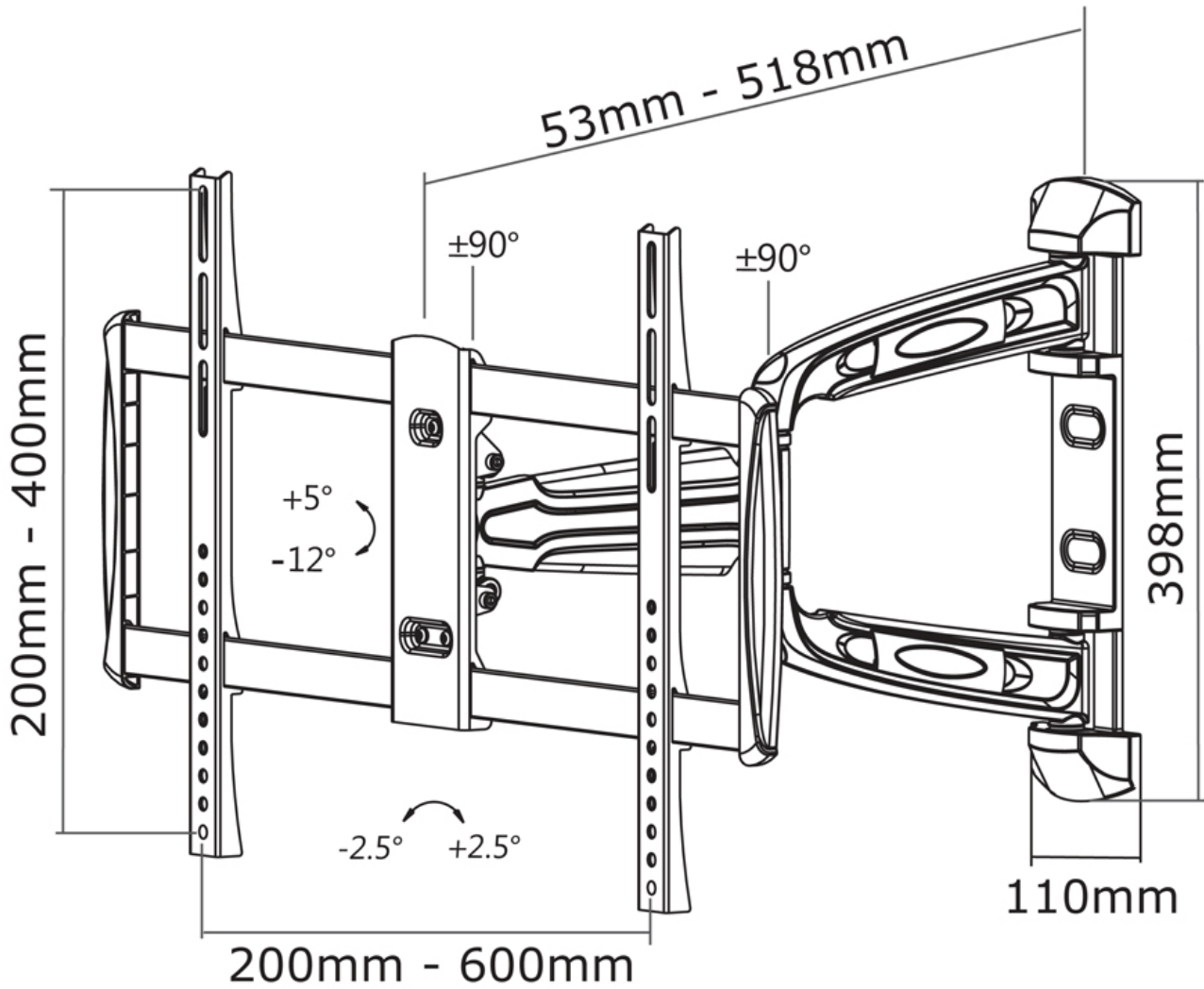

NewStar Products Europe B.V.  
Wateringweg 62/B  
2031 EJ HAARLEM  
THE NETHERLANDS

Phone : +31(0)23-5478888  
Fax : +31(0)23-5478889  
Email : info@newstar.nl  
Website : www.newstar.eu

NewStar cannot be held liable for any inaccuracies and copyrights.  
No part of this publication may be reproduced and/or published by print, photocopy, microfilm or in any other way, without prior written permission of NewStar Computer Products Europe BV.