



## FPMA-W915

## NEWSTAR FLAT SCREEN WALL MOUNT

Newstar TV/Monitor Wall Mount (2 pivots & tiltable) for 10"-40" Screen - Silver



### SPECIFICATIONS

Color	Silver
Distance to wall	12 cm
Height adjustment	None
Max. screen size	40
Max. weight	20
Min. screen size	10
Min. weight	0
Rotate (degrees)	360°
Screens	1
Swivel (degrees)	180°
Tilt (degrees)	15°
Type	Tilt Rotate Swivel Full motion
VESA maximum	200x200 mm
VESA minimum	75x75 mm
Warranty	5 year
EAN code	8717371441548

The NewStar wall mount, model FPMA-W915 is a tilt-, swivel and rotatable wall mount for flat screens up to 40". This mount is a great choice when you want the ultimate viewing flexibility with your flat screen. Effortless pull the display out from the wall, position it in almost any direction, turn it around corners and then smoothly return it to the wall when finished.

NewStars' tilt (15°), rotate (360°) and swivel (180°) technology allows the mount to change to any viewing angle to fully benefit from the capabilities of the flat screen. The mount is 12 centimetres deep.

NewStar FPMA-W915 has two pivot points and is suitable for screens up to 40" (102 cm). The weight capacity of this product is 20 kg each screen. The wall mount is suitable for screens that meet VESA hole pattern 75x75 to 200x200mm. Different hole patterns can be covered using NewStar VESA adapter plates.

Create a clean design ambiance for your flat screen TV in the living room, bedroom or home cinema.

All installation material is included with the product.



**THE BEST SUPPORT  
FOR YOUR AV & IT HARDWARE**  
T: +31(0)23-5478888 | E: info@newstar.eu | W: www.newstar.eu

## FPMA-W915

## NEWSTAR FLAT SCREEN WALL MOUNT

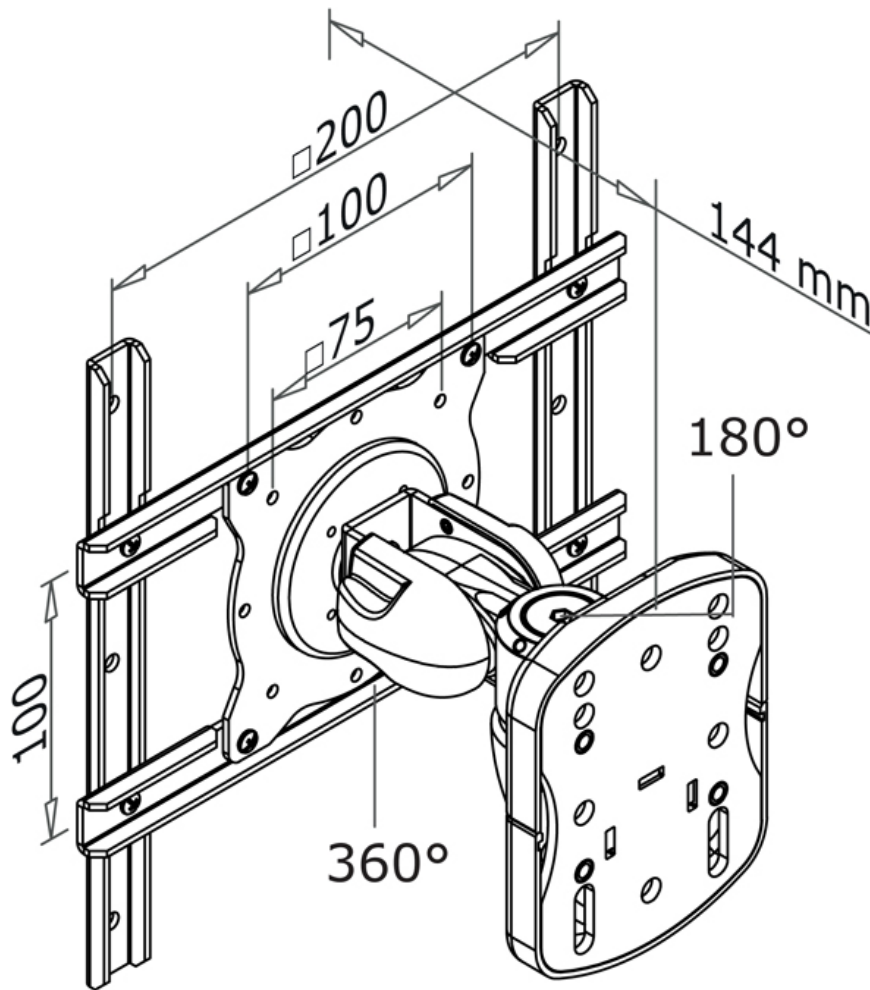

NewStar Products Europe B.V.  
Wateringweg 62/B  
2031 EJ HAARLEM  
THE NETHERLANDS

Phone : +31(0)23-5478888  
Fax : +31(0)23-5478889  
Email : info@newstar.nl  
Website : www.newstar.eu

NewStar cannot be held liable for any inaccuracies and copyrights.  
No part of this publication may be reproduced and/or published by print, photocopy, microfilm or in any other way, without prior written permission of NewStar Computer Products Europe BV.